

SVILUPPO CULTURALE E DEL LINGUAGGIO

Emidio Tribulato



Volume 12

Emidio Tribulato

SVILUPPO CULTURALE E DEL LINGUAGGIO

Centro studi *LOGOS* – ONLUS - Messina



2010- Tutti i diritti riservati.

Sito web: www.cslogos.it – E - mail: postmaster@cslogos.it

I SINONIMI (senza immagini)

Ogni scheda è formata da quattro gruppi di parole, il compito del bambino consiste nell' associare, in ogni gruppo, ogni parola con il rispettivo sinonimo. Quest'attività gli potrà permettere di esercitarsi nella lettura, di acquisire un vocabolario più ricco di termini e di migliorare la comprensione di quelli già appresi.

UTILIZZAZIONE

SCELTA MULTIPLA INCROCIATA

Per stimolare l'apprendimento s'inviterà il bambino a leggere, le parole che si trovano nella parte sinistra di ogni gruppo collegandole con i sinonimi che si trovano nella parte destra.

In quest'attività il bambino sarà facilitato dal sistema di risposta a scelta multipla incrociata, che gli permetterà di collegare, per esclusione, anche i termini che non conosce, poiché potrà iniziare da quelli a lui noti.

ETÁ DI RIFERIMENTO

Sviluppo linguistico ed intellettuale di almeno sette anni.

GLORIA

INGROSSARE

ONORARE

PROGETTO

GONFIARE

RIDICOLO

OPERAZIONE

IDEA

GOFFO

TRIONFO

OPINIONE

RISPETTARE

POSIZIONE

CIBO

ACCORDO

PATTO

PRESSIONE

COLLOCAZIONE

ACINO

CHICCO

PIETANZA

BISOGNO

ADDOBBO

DECORAZIONE

I SINONIMI

Far associare, per ogni gruppo, ogni parola con il suo sinonimo.

DIALOGARE

COMUNICARE

SCAFFALE

BARCA

DIFENDERE

TUTELA

SCAFO

MENSOLA

DIFESA

PROTEGGERE

SCALTRO

ABILE

OCCUPARE

OSCURITA'

URTO

COLPO

OMBRA

IMPEGNARE

USANZA

PASSEGGIATA

ONDA

CAVALLONE

USCITA

TRADIZIONE

I SINONIMI

Far associare, per ogni gruppo, ogni parola con il suo sinonimo.

UBBIDIENTE

BRILLO

TUFFO

IMMERSIONE

UBRIACO

PARITA'

TURNO

SCAMBIO

UGUAGLIANZA

DOCILE

TRASPORTARE

TRASFERIRE

SANTO

BENEDETTO

TERRA

FORTUNA

SBADATO

DOTTO

TESORO

PANNO

SAPIENTE

DISATTENTO

TESSUTO

SUOLO

I SINONIMI

Far associare, per ogni gruppo, ogni parola con il suo sinonimo.

MACCHINISTA

AFFASCINANTE

VERIFICA

ESPOSIZIONE

MAGAZZINO

AUTISTA

VETRINA

PROVA

MAGNIFICO

DEPOSITO

VIGORE

CORAGGIO

RAMO

VAGABONDO

CORNICE

GALOPPARE

RANDAGIO

FINZIONE

CORREGGERE

CONTORNO

RECITA

FRASCA

CORRERE

PERFEZIONARE

I SINONIMI

Far associare, per ogni gruppo, ogni parola con il suo sinonimo.

GARBO

LANCIARE

DEFINITIVO

PIACEVOLE

GETTARE

CORTESIA

DELIZIOSO

CONCLUSIVO

GIOIELLO

GEMMA

DENARO

CAPITALE

SALVEZZA

SGOMBERARE

VARCO

BARCA

SBARAZZARE

SATIRICO

VARIAZIONE

APERTURA

SPIRITOSO

GRAZIA

VASCELLO

CAMBIAMENTO

I SINONIMI

Far associare, per ogni gruppo, ogni parola con il suo sinonimo.

GLI AGGETTIVI

Gli aggettivi qualificativi servono a conferire ai nomi e agli oggetti qualità, caratteristiche o attributi. La loro conoscenza ed il loro uso specifico serve ad arricchire il linguaggio e la cultura degli allievi. Ci è sembrato pertanto opportuno inserire nei vari livelli del programma base, mediante un sistema a scelta multipla, un gran numero di aggettivi dai più semplici ai più complessi, da associare a immagini di oggetti, animali, persone o situazioni.

Questa attività permette di conoscere meglio e ampliare le caratteristiche fondamentali di ogni elemento rappresentato, mentre nel contempo viene ad essere stimolata la riflessione sulle qualità presenti negli oggetti ed esseri viventi.

UTILIZZAZIONE

Mentre i bambini che sanno leggere indicheranno e denomineranno semplicemente l'oggetto a cui si riferisce il contenuto della frase, per gli altri sarà l'insegnante o l'educatore che leggerà la breve frase ed il bambino dovrà solo indicare, denominandola, l'immagine corrispondente.

ETA' DI RIFERIMENTO

Sette anni di sviluppo linguistico ed intellettuale.

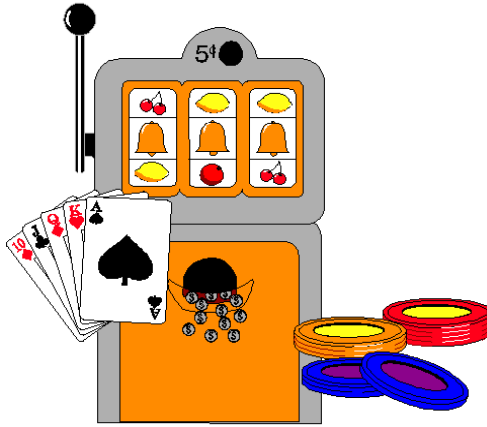

- Mangiabile come...
- Mangia Soldi come...
- Preciso come...

GLI AGGETTIVI

Associa ogni aggettivo all'immagine corrispondente.



- Migliore come...
- Addolorata come...
- Esatto come...

GLI AGGETTIVI

Associa ogni aggettivo all'immagine corrispondente.

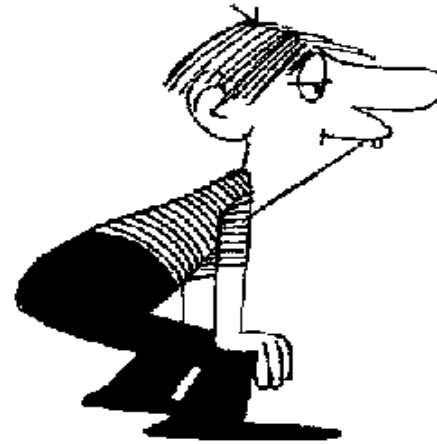
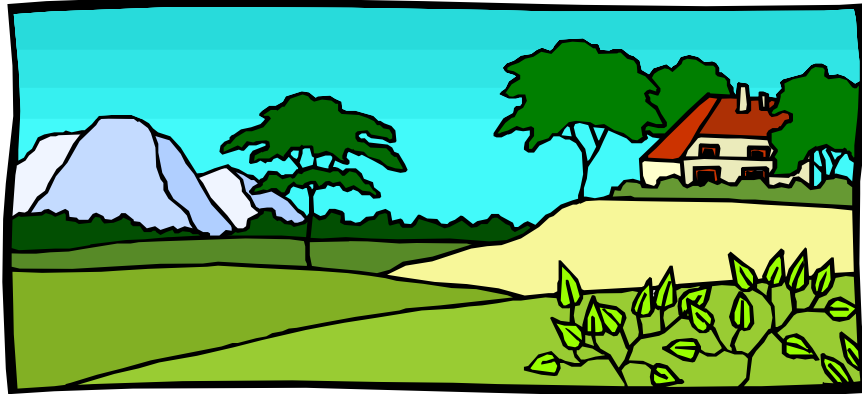

- Debole come...
- Forte come...
- Campestre come...

GLI AGGETTIVI

Associa ogni aggettivo all'immagine corrispondente.

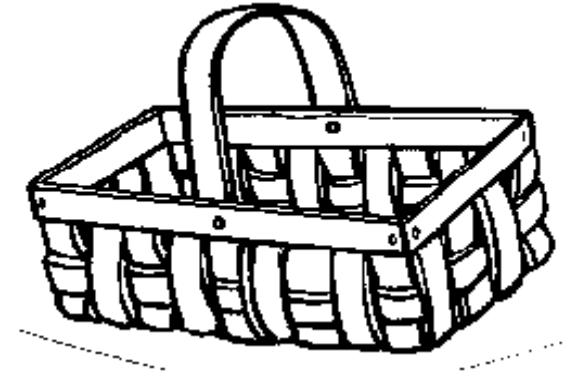
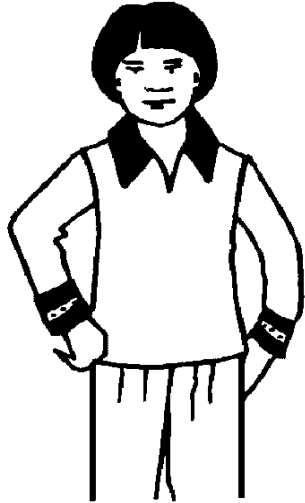

- Senile come...
- Vacante come...
- Baldo come...

GLI AGGETTIVI

Associa ogni aggettivo all'immagine corrispondente.

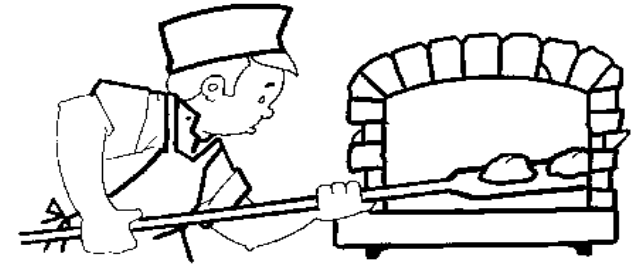

- Tuttofare come...
 - Minore come...
 - Artigianale come...

GLI AGGETTIVI

Associa ogni aggettivo all'immagine corrispondente.



- Malaugurato come...
- Suntuoso come...
- Ottenibile come...

GLI AGGETTIVI

Associa ogni aggettivo all'immagine corrispondente.

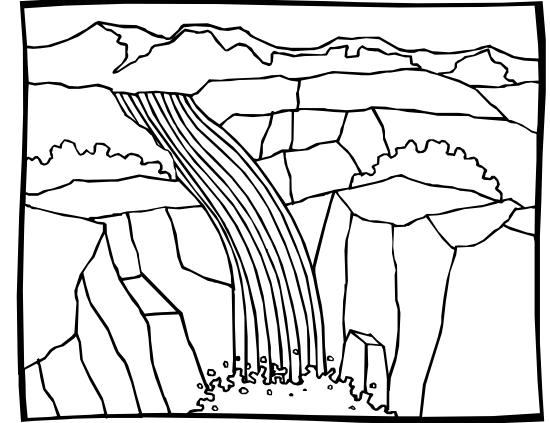

- Erosivo come...
- Lacrimosa come...
- Lupesco come...

GLI AGGETTIVI

Associa ogni aggettivo all'immagine corrispondente.

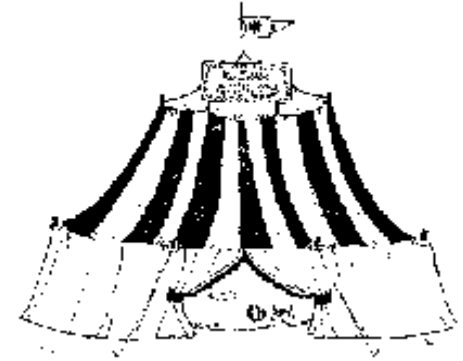

- Coperto come...
- Fumoso come...
- Simile come...

GLI AGGETTIVI

Associa ogni aggettivo all'immagine corrispondente.

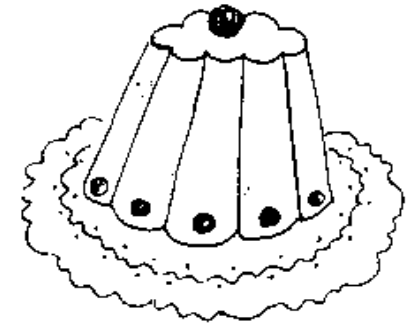
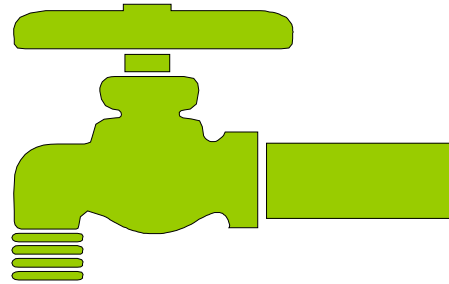

- Gelatinoso come...
- Idrologico come...
- Fiscale come...

GLI AGGETTIVI

Associa ogni aggettivo all'immagine corrispondente.

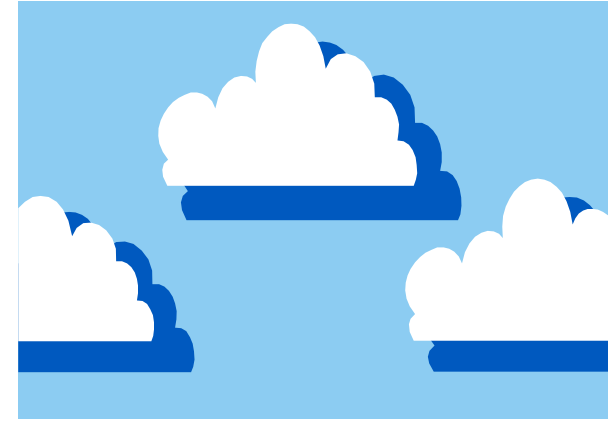
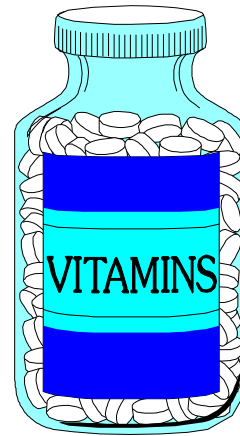
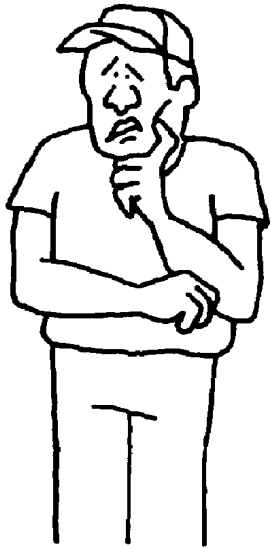

- Celeste come...
- Ricostituente come...
- Sospiroso come...

GLI AGGETTIVI

Associa ogni aggettivo all'immagine corrispondente.

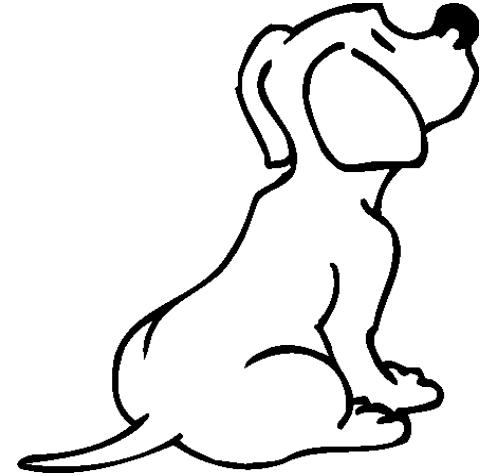
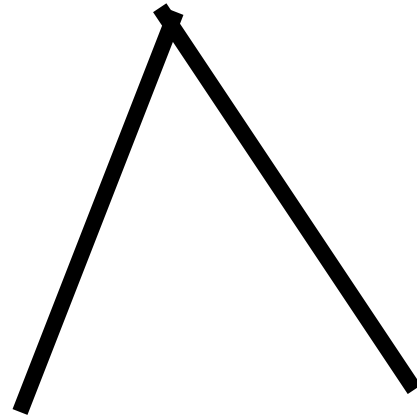

- Fedele come...
- Convergente come...
- Famelico come...

GLI AGGETTIVI

Associa ogni aggettivo all'immagine corrispondente.

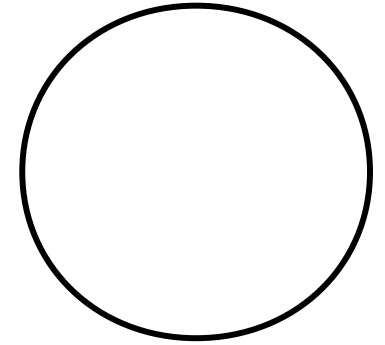
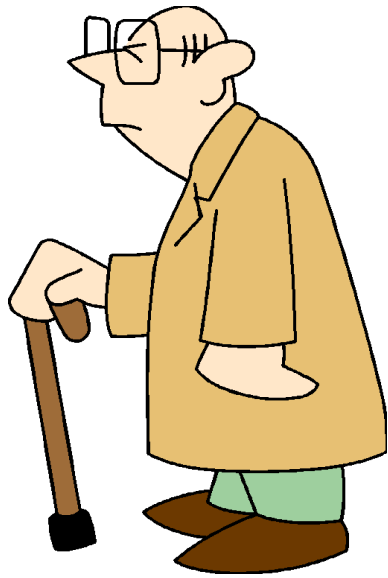

- Semplice come...
- Intonata come...
- Senile come...

GLI AGGETTIVI

Associa ogni aggettivo all'immagine corrispondente.

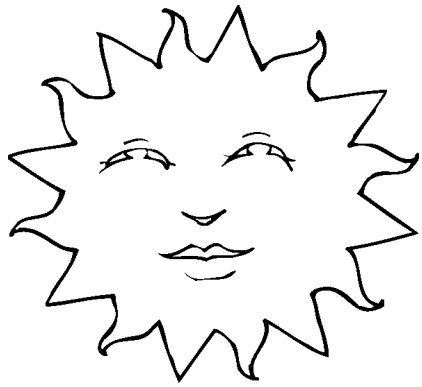

- Ottimistico come...
- Malconco come...
- Luminoso come...

GLI AGGETTIVI

Associa ogni aggettivo all'immagine corrispondente.

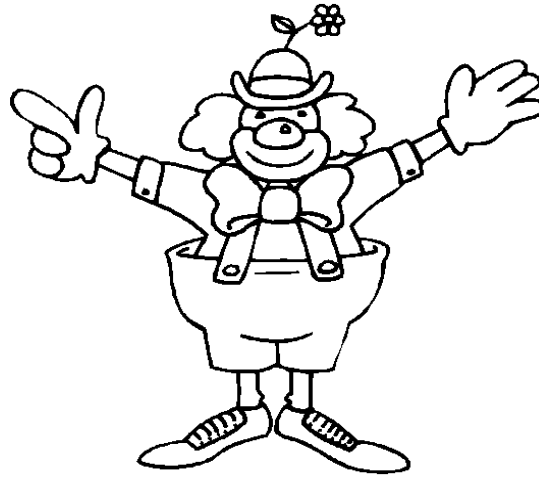

- Comico come...
- Leale come...
- Negativo come...

GLI AGGETTIVI

Associa ogni aggettivo all'immagine corrispondente.

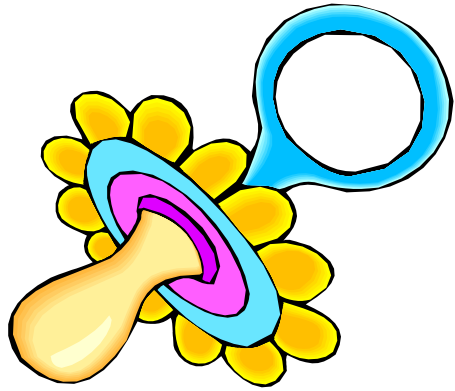

- Facile come...
- Ritmico come...
- Deformabile come...

GLI AGGETTIVI

Associa ogni aggettivo all'immagine corrispondente.

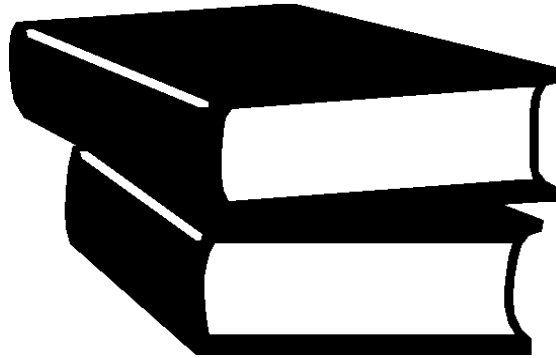
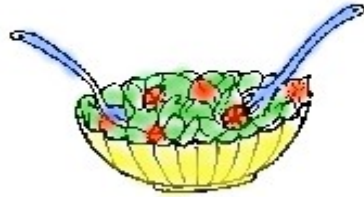

- Festivo come...
 - Contorno come...
 - Concreto come...

GLI AGGETTIVI

Associa ogni aggettivo all'immagine corrispondente.

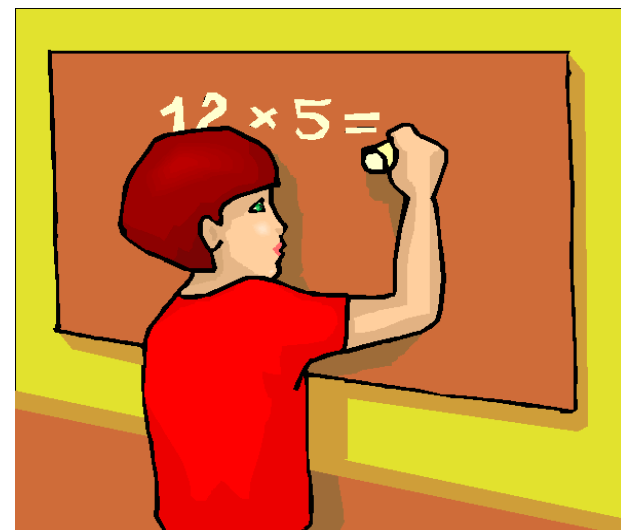
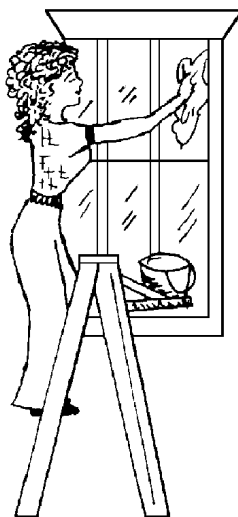

- Risolubile come...
- Solerte come...
- Amabile come...

GLI AGGETTIVI

Associa ogni aggettivo all'immagine corrispondente.

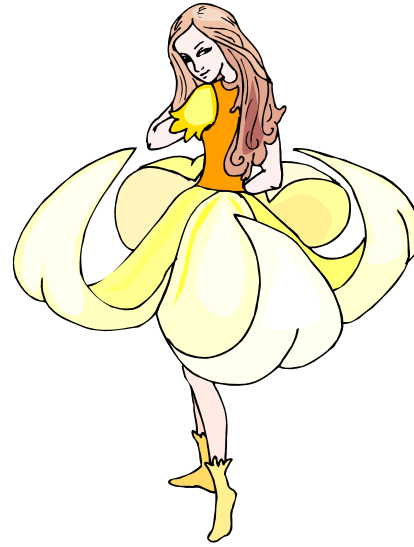

- Leggiadra come...
- Conciliante come...
- Dolorosa come...

GLI AGGETTIVI

Associa ogni aggettivo all'immagine corrispondente.

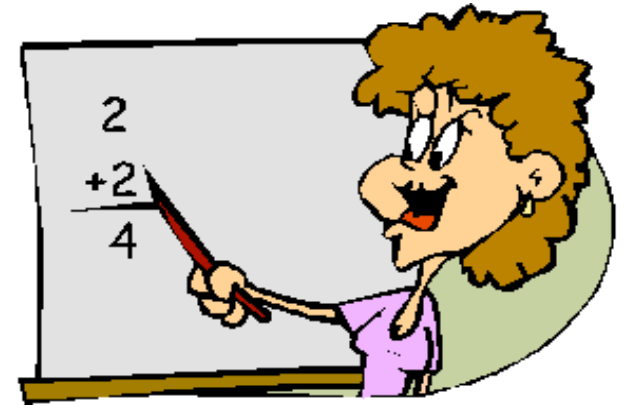

- Dotto come...
- Triste come...
- Concisa come...

GLI AGGETTIVI

Associa ogni aggettivo all'immagine corrispondente.



- Materno come...
- Materiale come...
- Sovrano come...

GLI AGGETTIVI

Associa ogni aggettivo all'immagine corrispondente.

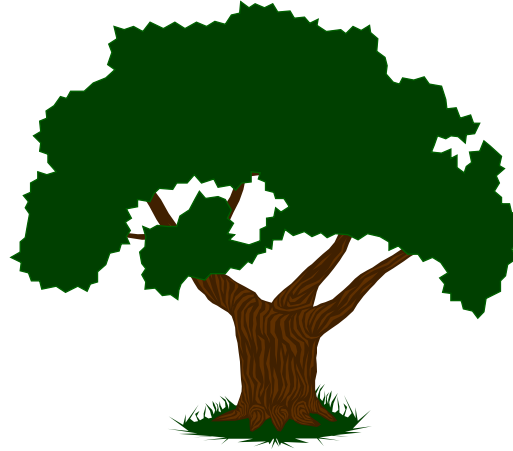

- Ombroso come...
- Accordato come...
- Rustico come...

GLI AGGETTIVI

Associa ogni aggettivo all'immagine corrispondente.

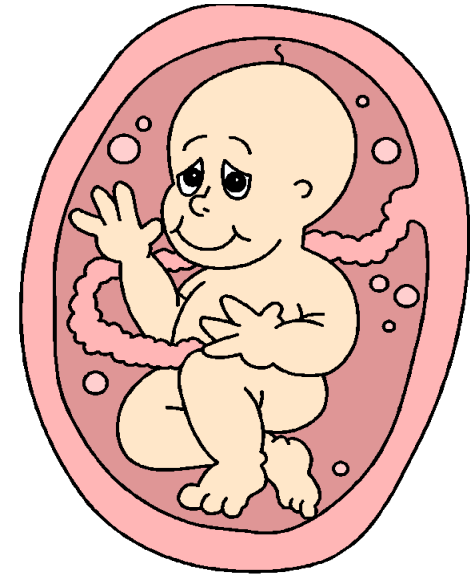
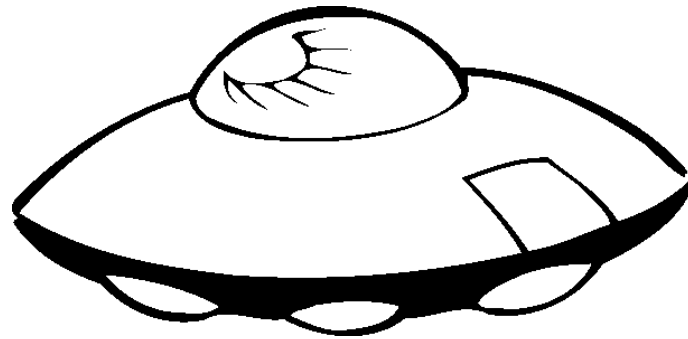

- Protetto come...
- Alieno come...
- Coraggioso come...

GLI AGGETTIVI

Associa ogni aggettivo all'immagine corrispondente.

LINGUAGGIO : ASSOCIAZIONI VERBALI

In queste schede sono presenti tre brevi frasi da collegare per il loro significato a tre immagini.

- Lo scopo è quello di stimolare la comprensione dei nomi e delle espressioni linguistiche presenti nella frase, ciò porterà, naturalmente, a una maggiore ricchezza del vocabolario del bambino.
- Nel momento in cui vengono richieste l'uso, la funzione, il significato o le caratteristiche dell'immagine presentata, abbiamo la possibilità di aiutare il bambino a sviluppare sia gli elementi culturali che il linguaggio espressivo.

UTILIZZAZIONE

Prima fase

Per stimolare la comprensione verbale si leggerà o si farà leggere la prima frase ed il bambino dovrà indicare l'immagine a cui si riferisce, lo stesso si farà con le successive.

Seconda fase

In un secondo tempo per stimolare l'espressione verbale facendo osservare l'immagine disegnata e rispettando il contenuto delle frasi scritte, si chiederà l'uso, la funzione, o qualche caratteristica dell'oggetto rappresentato.

Naturalmente per i bambini che sanno leggere si copriranno le frasi scritte per evitare che possano decifrare le risposte.

ETÀ DI RIFERIMENTO

Sviluppo linguistico e intellettuale di almeno otto anni.

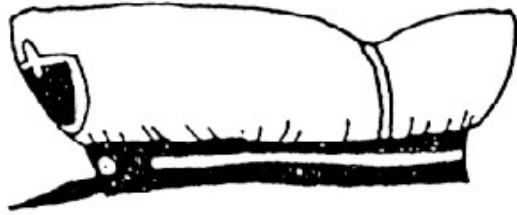

- I motociclisti usano...
- I montanari usano...
- I vigili urbani usano...

ASSOCIAZIONI VERBALI

Far associare ogni frase all'immagine corrispondente.

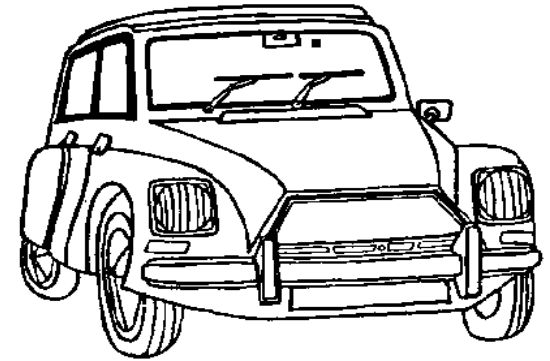
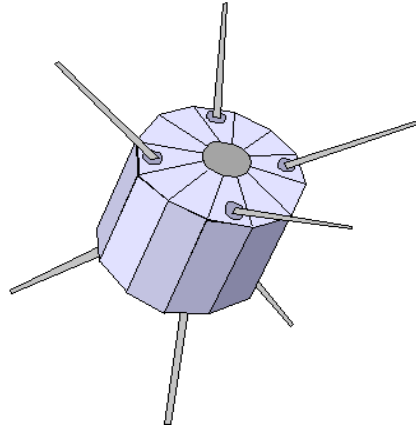
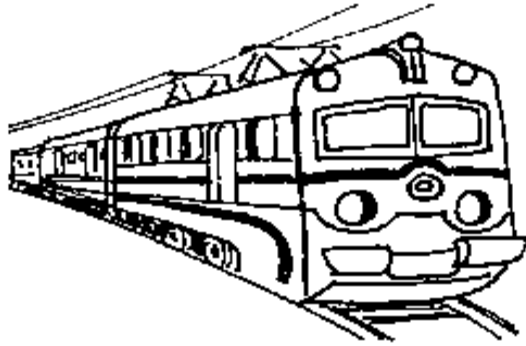

- Ha le ruote ed il volante.
- Ha le ruote ma non il volante.
- Non ha né le ruote né il volante.

ASSOCIAZIONI VERBALI

Far associare ogni frase all'immagine corrispondente.

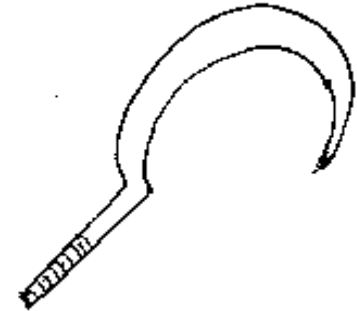
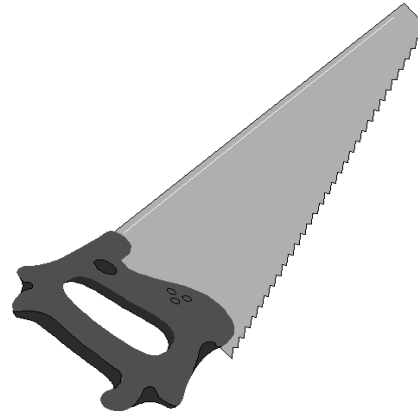

- Si taglia l'erba con...
 - Si vanga la terra con...
 - Si tagliano i grossi rami con...

ASSOCIAZIONI VERBALI

Far associare ogni frase all'immagine corrispondente.

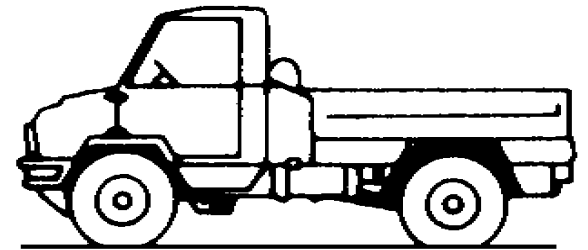
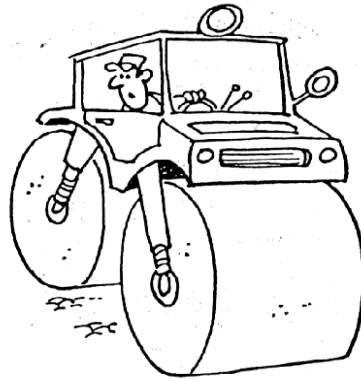
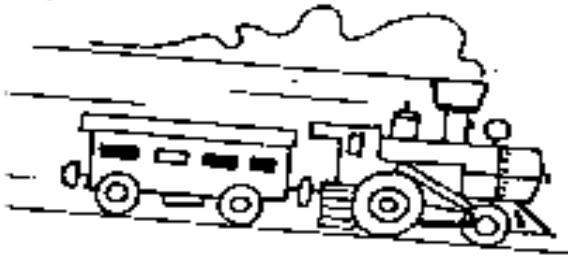

- Sbuffa.
 - Trasporta.
 - Schiaccia i sassi.

ASSOCIAZIONI VERBALI

Far associare ogni frase all'immagine corrispondente.

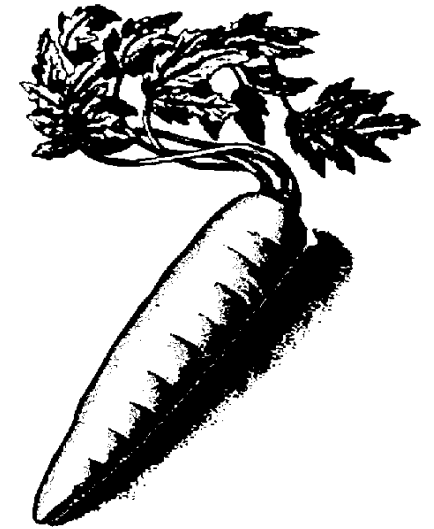
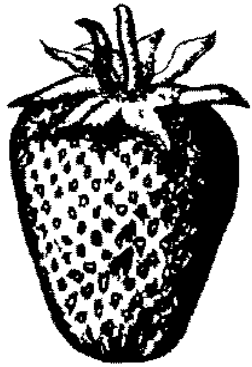

- E' un ortaggio.
- E' un ramo.
- E' un frutto.

ASSOCIAZIONI VERBALI

Far associare ogni frase all'immagine corrispondente.

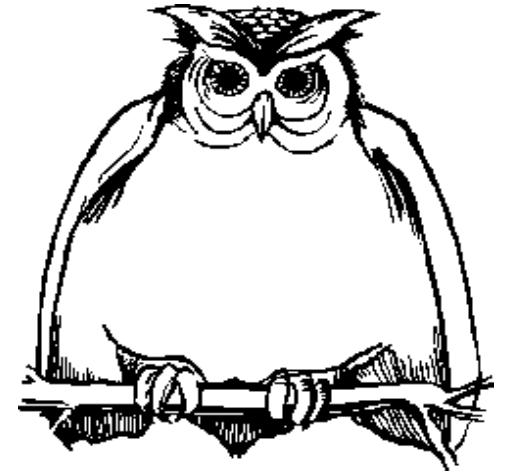
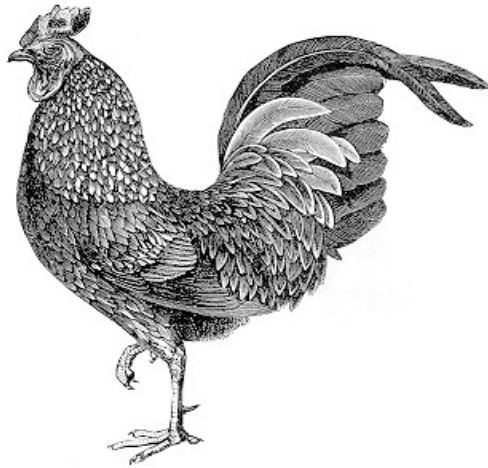

- Di notte fa sentire la sua voce...
- Di giorno parla...
- All'alba canta...

ASSOCIAZIONI VERBALI

Far associare ogni frase all'immagine corrispondente.

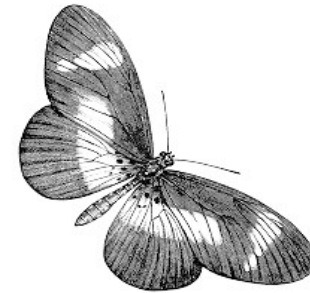
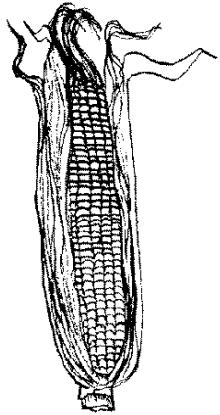

- Nei prati catturo...
- Nei boschi raccolgo...
- Nelle campagne raccolgo...

ASSOCIAZIONI VERBALI

Far associare ogni frase all'immagine corrispondente.

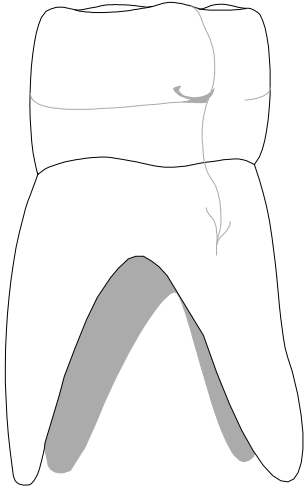

- Ha quattro cavità per pompare.
 - Ha la corona e le radici per masticare.
 - Ha il tallone e le dita per camminare.

ASSOCIAZIONI VERBALI

Far associare ogni frase all'immagine corrispondente.

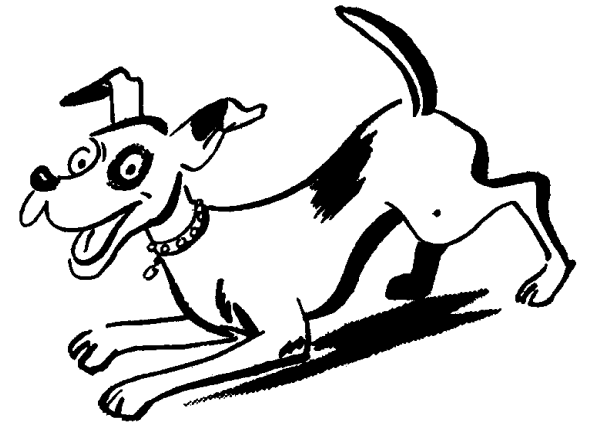
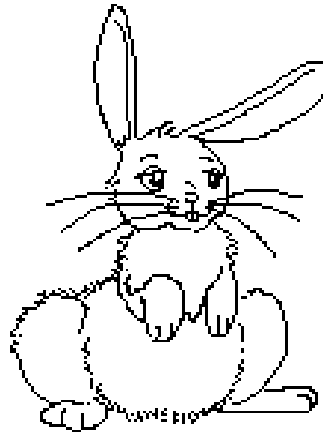
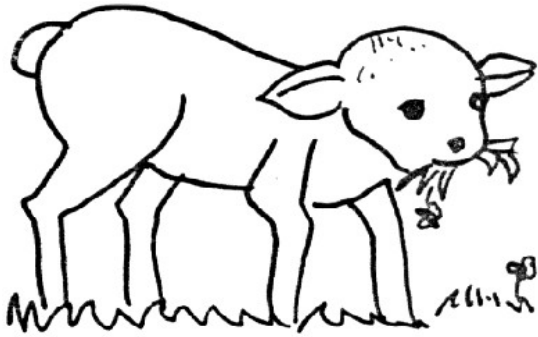

- Vive nel canile.
 - Vive nell'ovile.
 - Vive nella tana.

ASSOCIAZIONI VERBALI

Far associare ogni frase all'immagine corrispondente.

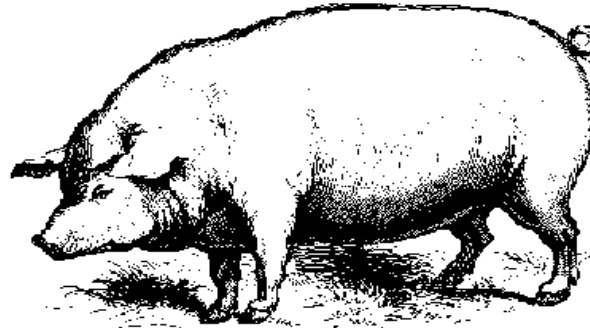

- Gracchia.
- Ruggisce.
- Grugnisce.

ASSOCIAZIONI VERBALI

Far associare ogni frase all'immagine corrispondente.

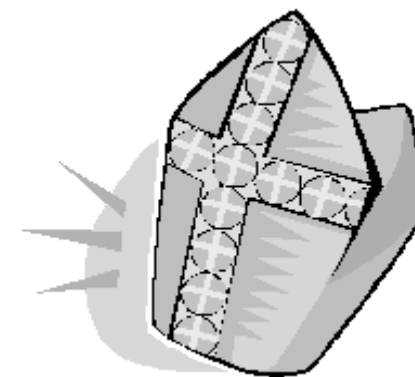

- Gli esploratori usano...
- I corazzieri usano...
- I vescovi usano...

ASSOCIAZIONI VERBALI

Far associare ogni frase all'immagine corrispondente.

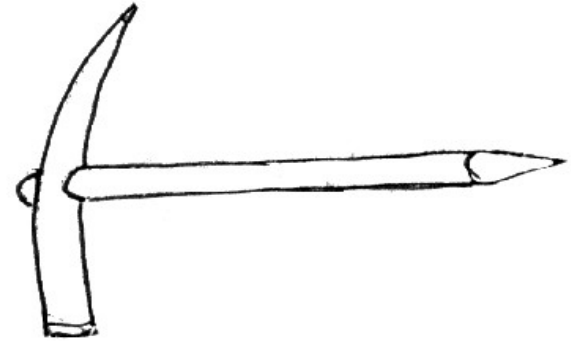
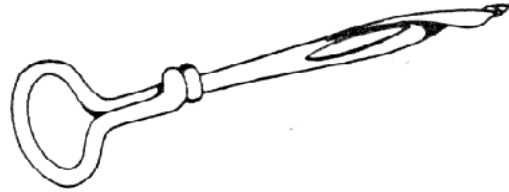
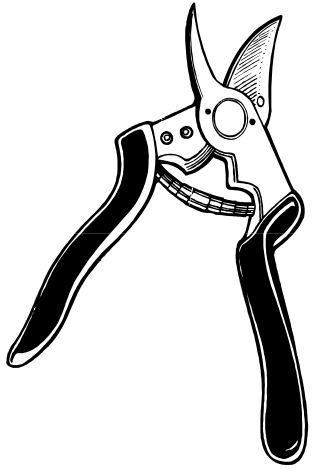

- L'alpinista usa...
- Il calzolaio usa...
- Il giardiniere usa...

ASSOCIAZIONI VERBALI

Far associare ogni frase all'immagine corrispondente.

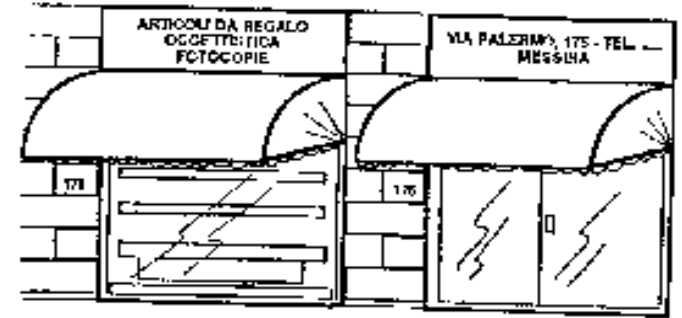
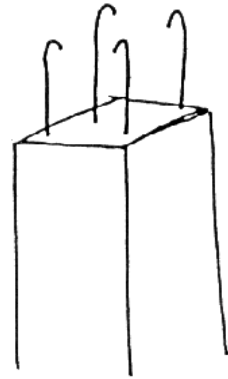
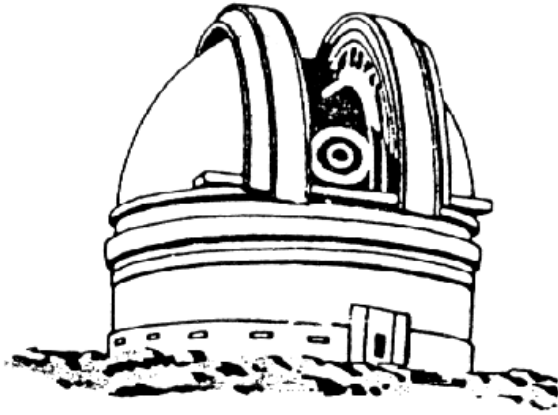

- Sta nei muri delle case.
 - Sta nelle strade delle città.
 - Sta sulla montagna.

ASSOCIAZIONI VERBALI

Far associare ogni frase all'immagine corrispondente.

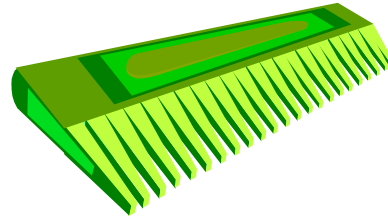
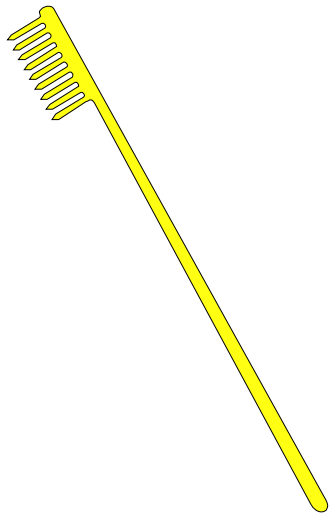

- Ha i denti.
- Ha le setole.
- Ha i buchi.

ASSOCIAZIONI VERBALI

Far associare ogni frase all'immagine corrispondente.

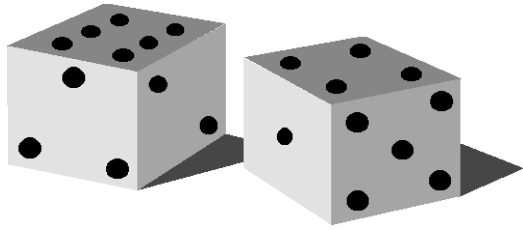

- Ascolto dal vivo la musica suonata...
 - Gioco con...
 - Ascolto la musica registrata...

ASSOCIAZIONI VERBALI

Far associare ogni frase all'immagine corrispondente.



- Ha i mari, i fiumi ed i continenti.
- Ha molti anelli.
- Ha molti crateri.

ASSOCIAZIONI VERBALI

Far associare ogni frase all'immagine corrispondente.

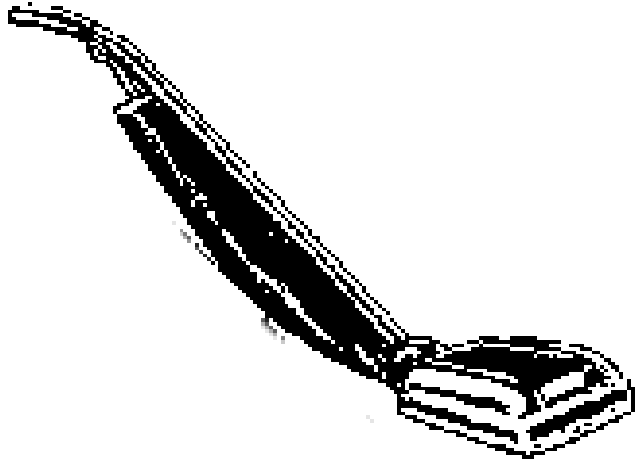

- Ha la cornetta.
- Ha il paralume.
- Ha il motore.

ASSOCIAZIONI VERBALI

Far associare ogni frase all'immagine corrispondente.

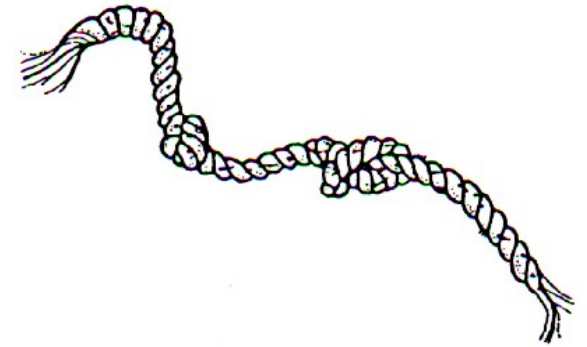
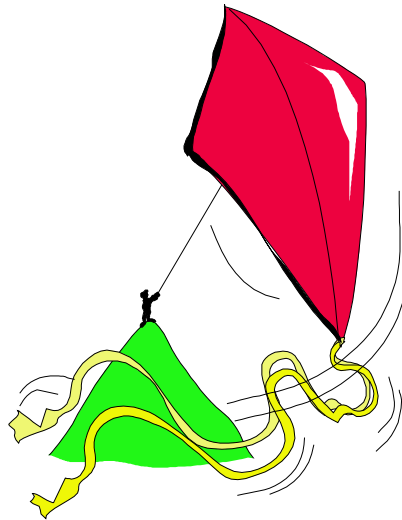
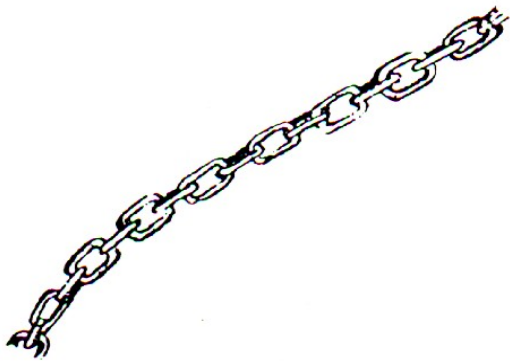

- Ha i nodi.
- Ha le maglie.
- Ha la coda.

ASSOCIAZIONI VERBALI

Far associare ogni frase all'immagine corrispondente.

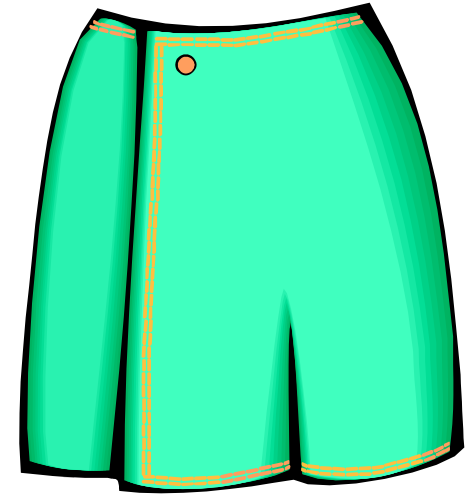
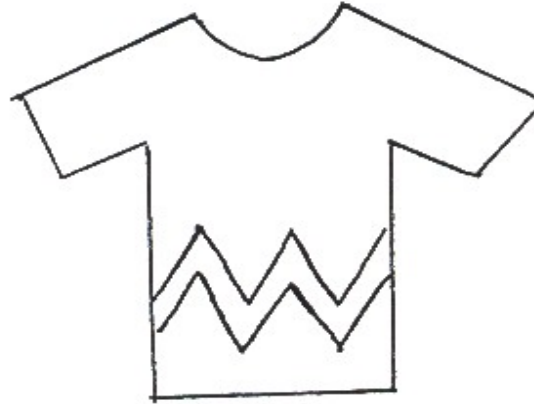
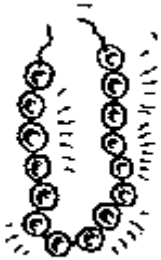

- Metto sul torace...
- Metto sui fianchi...
- Metto al collo...

ASSOCIAZIONI VERBALI

Far associare ogni frase all'immagine corrispondente.

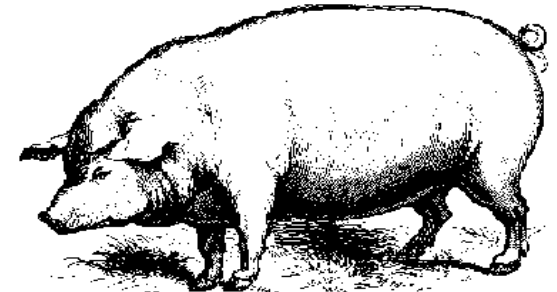
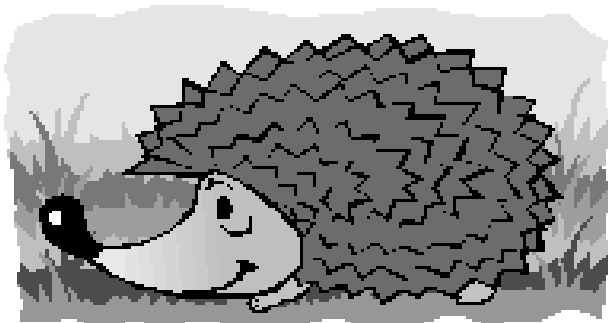

- Ha il corpo ricoperto di setole dure.
- Ha il corpo ricoperto di spine.
- Ha il corpo ricoperto di morbida pelliccia.

ASSOCIAZIONI VERBALI

Far associare ogni frase all'immagine corrispondente.

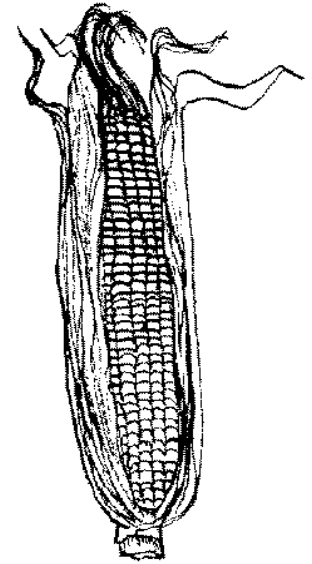
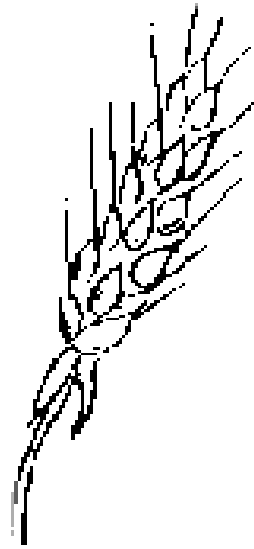

- Porta molti semi nella spiga.
- Ha molti semi nella pannocchia.
- Porta molti semi nel baccello.

ASSOCIAZIONI VERBALI

Far associare ogni frase all'immagine corrispondente.

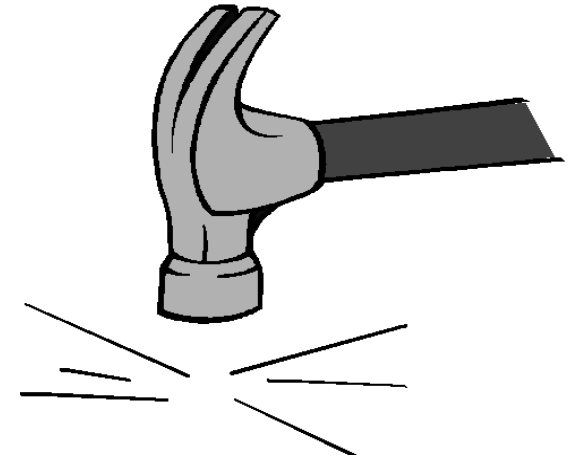
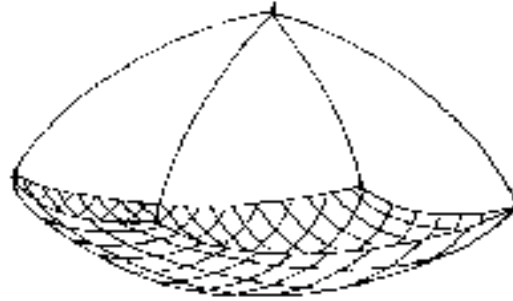
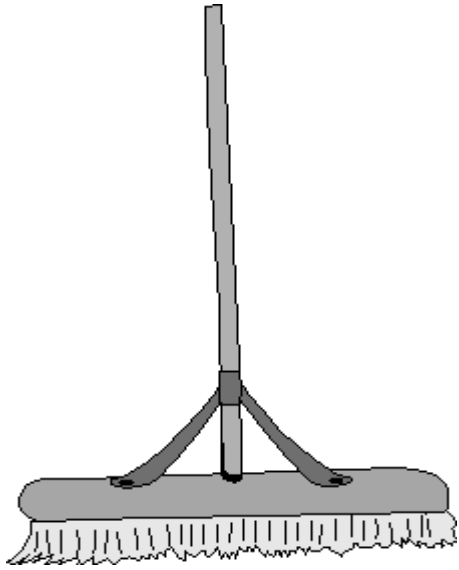

- Ha le maglie.
- Ha la testa.
- Ha le setole.

ASSOCIAZIONI VERBALI

Far associare ogni frase all'immagine corrispondente.

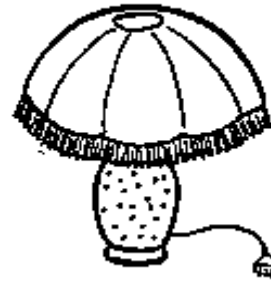
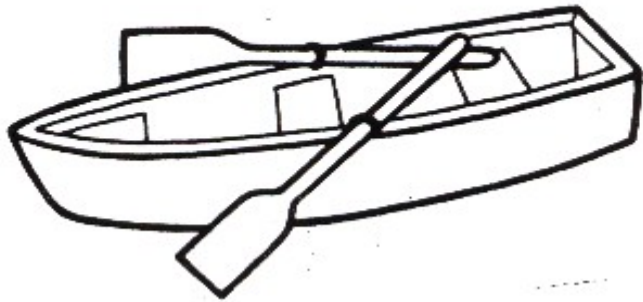

- L'idraulico ripara...
- L'elettricista ripara...
- Il carpentiere ripara...

ASSOCIAZIONI VERBALI

Far associare ogni frase all'immagine corrispondente.

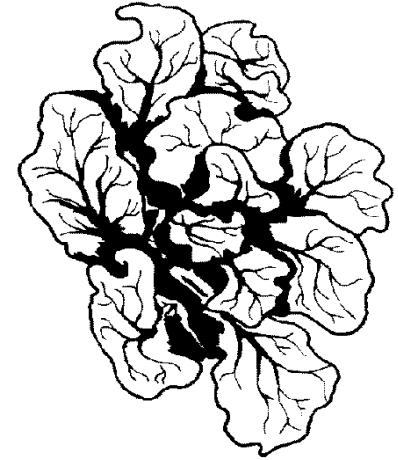

- Dall'orto raccolgo...
- Nei boschi raccolgo...
- Nelle campagne raccolgo...

ASSOCIAZIONI VERBALI

Far associare ogni frase all'immagine corrispondente.

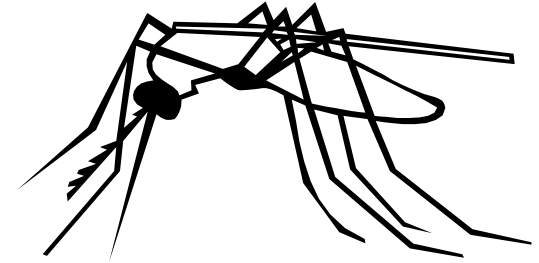
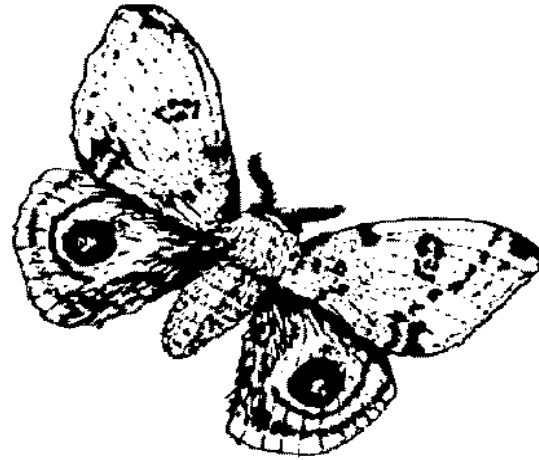
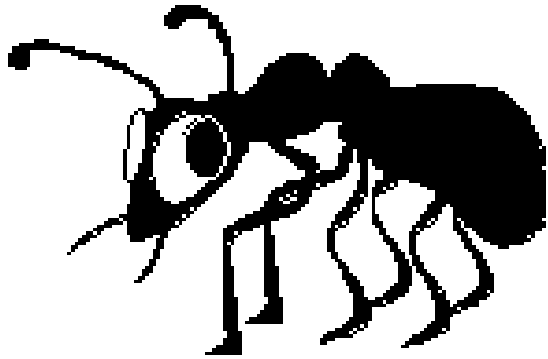

- E' un grande variopinto insetto.
- E' un piccolo laborioso insetto.
- E' un piccolo fastidioso insetto.

ASSOCIAZIONI VERBALI

Far associare ogni frase all'immagine corrispondente.

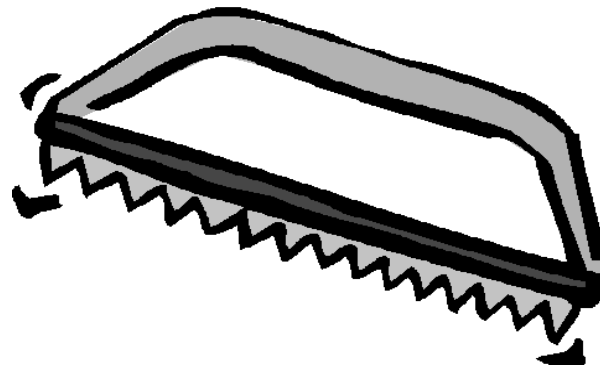
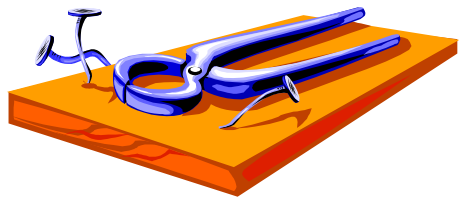

- Tolgo i chiodi con...
- I bulloni li avvito e svito con...
- Taglio il ferro con...

ASSOCIAZIONI VERBALI

Far associare ogni frase all'immagine corrispondente.

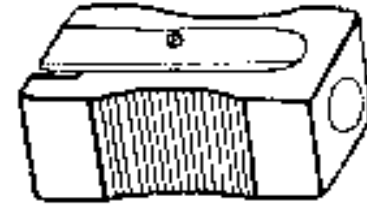
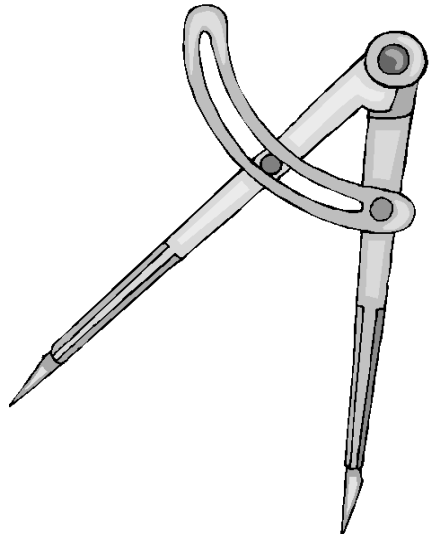

- Ha la lama.
- Ha la punta.
- Ha l'inchostro.

ASSOCIAZIONI VERBALI

Far associare ogni frase all'immagine corrispondente.

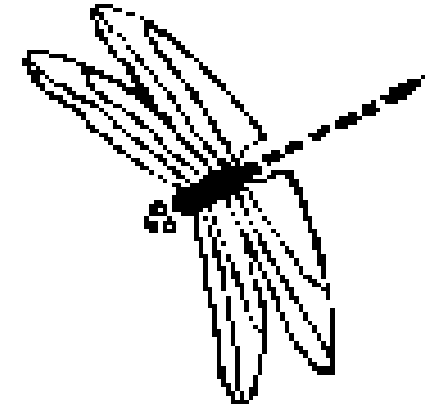
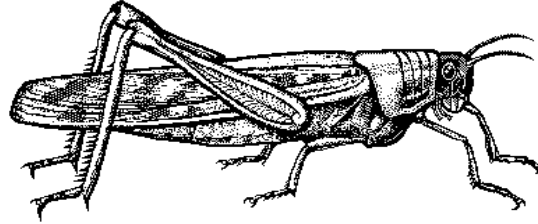
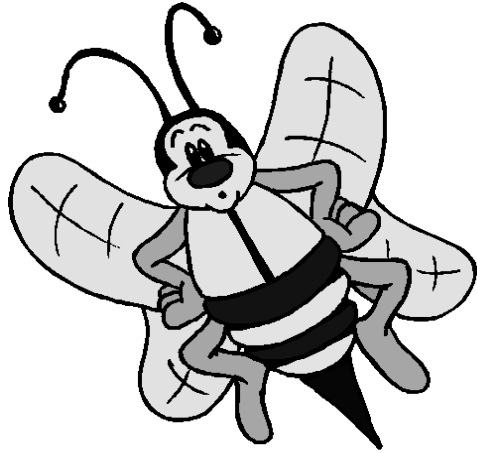

- Ha grandi ali ed un lungo corpo.
 - Ha un lungo pungiglione e ronza.
 - Ha grandi zampe per saltare e variopinte ali per volare.

ASSOCIAZIONI VERBALI

Far associare ogni frase all'immagine corrispondente.

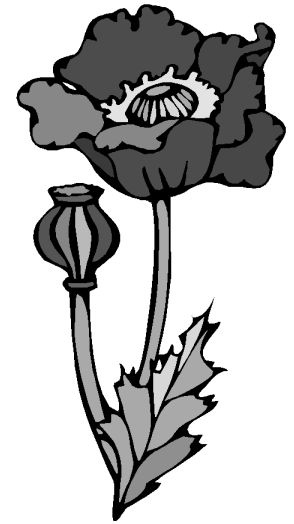
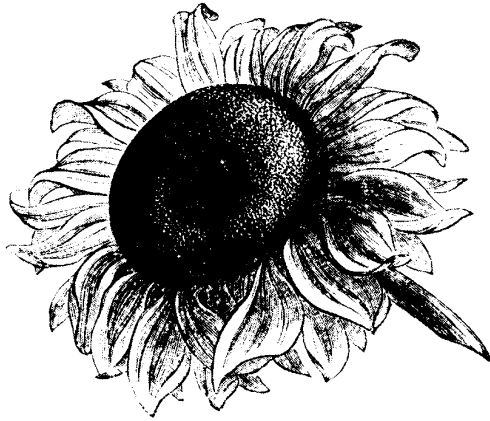

- E' un piccolo fiore di colore bianco ed è amato dalle spose.
- E' un fiore di colore rosso ed abbellisce i campi.
- E' un grande fiore di colore giallo e porta molti semi.

ASSOCIAZIONI VERBALI

Far associare ogni frase all'immagine corrispondente.

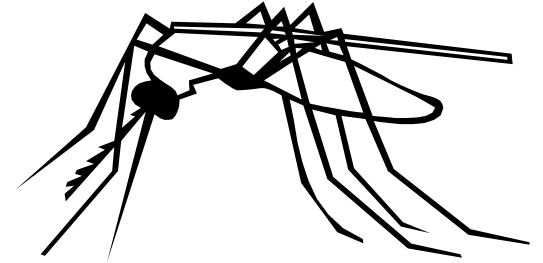
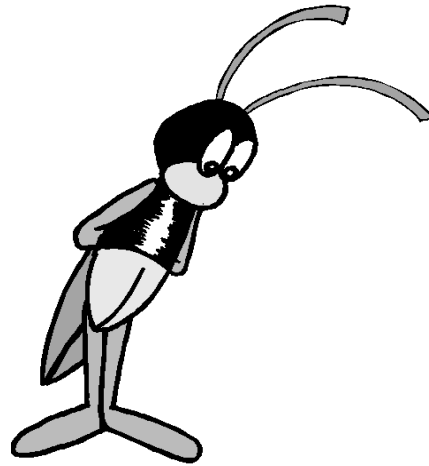

- Ronza.
- Vagisce.
- Canta.

ASSOCIAZIONI VERBALI

Far associare ogni frase all'immagine corrispondente.

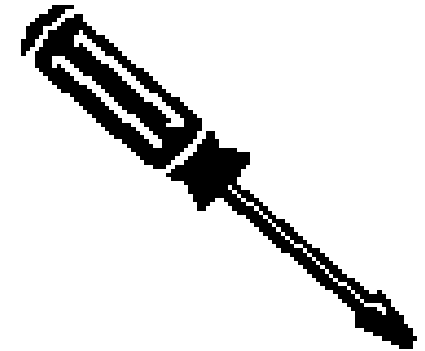
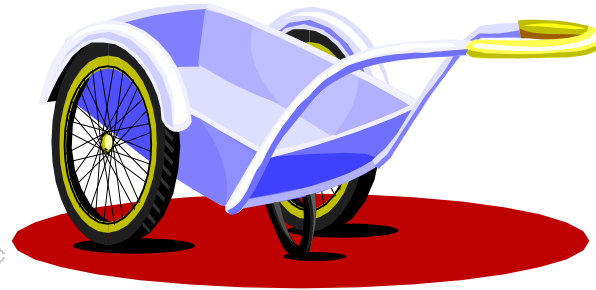
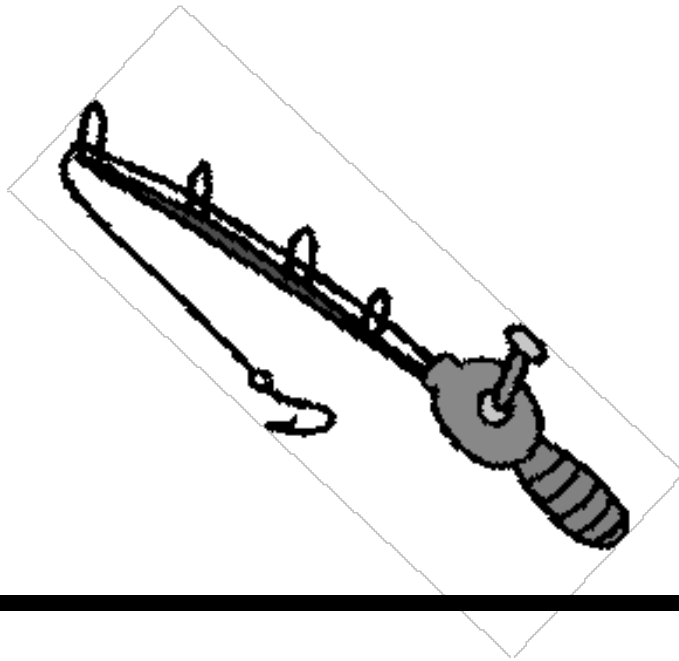

- Ha il mulinello.
- Ha la punta.
- Ha la ruota.

ASSOCIAZIONI VERBALI

Far associare ogni frase all'immagine corrispondente.

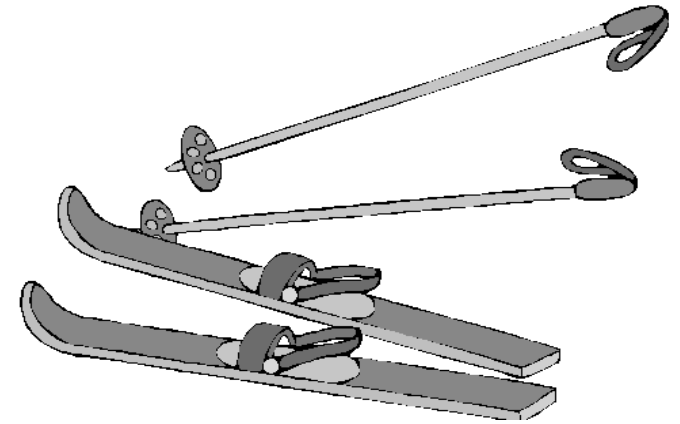
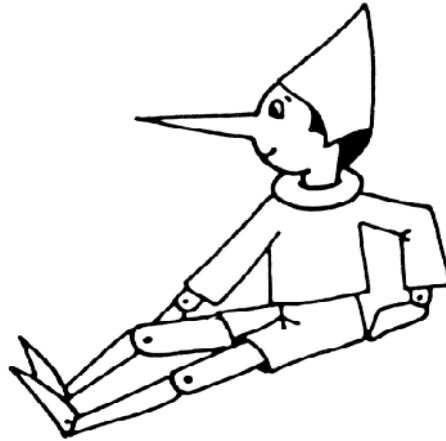
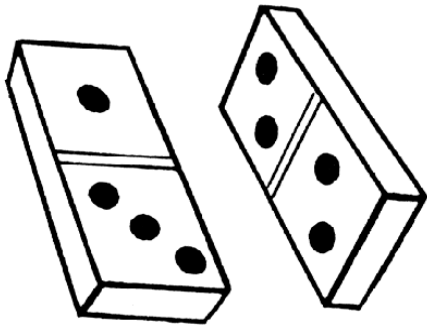

- Ha i bastoni.
- Ha le articolazioni.
- Ha le quantità.

ASSOCIAZIONI VERBALI

Far associare ogni frase all'immagine corrispondente.

CONFRONTARE

Il confrontare l'utilità, le grandezze, l'uso e le caratteristiche di oggetti, animali, vegetali, strumenti, mestieri ecc. caratterizza questo gruppo di schede.

Questa attività permette di conoscere meglio le caratteristiche fondamentali di ogni elemento rappresentato e stimola nel contempo la riflessione sulle qualità presenti negli oggetti ed esseri viventi.

Si migliora in questo modo la ricchezza del linguaggio e si affinano le capacità logiche.

UTILIZZAZIONE

Mentre i bambini che sanno leggere indicheranno e denomineranno semplicemente l'oggetto a cui si riferisce il contenuto della frase, per gli altri sarà l'insegnante o l'educatore che leggerà la breve frase ed il bambino dovrà solo indicare, denominandola, l'immagine corrispondente.

ETA' DI RIFERIMENTO

Otto anni di sviluppo linguistico ed intellettuale.



- L'animale più piccolo.
 - L'animale con le orecchie più lunghe.
 - L'animale con il corpo più spinoso.

CONFRONTARE

Far associare ogni frase all'immagine corrispondente.

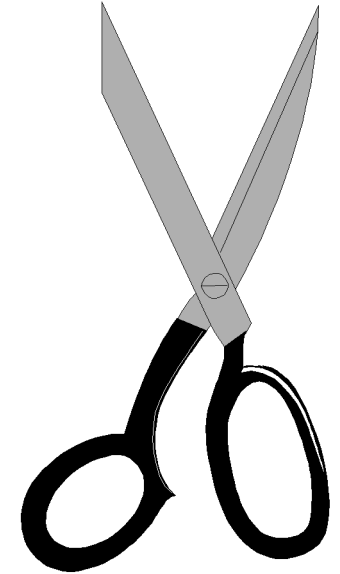
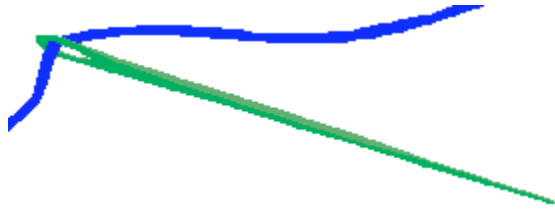

- L'oggetto più appuntito.
- L'oggetto meno appuntito.

CONFRONTARE

Far associare ogni frase all'immagine corrispondente.

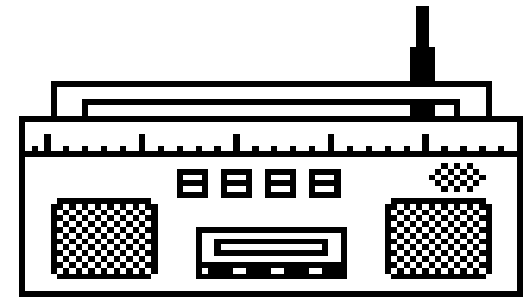
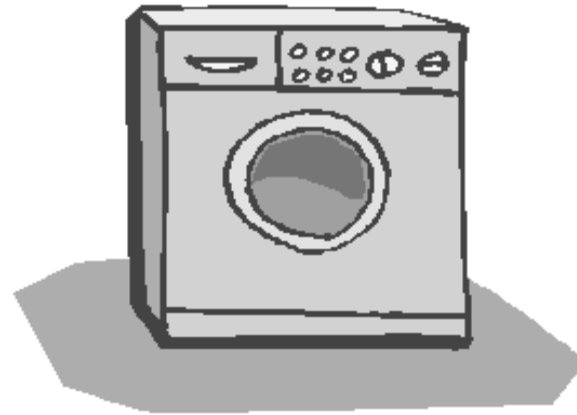
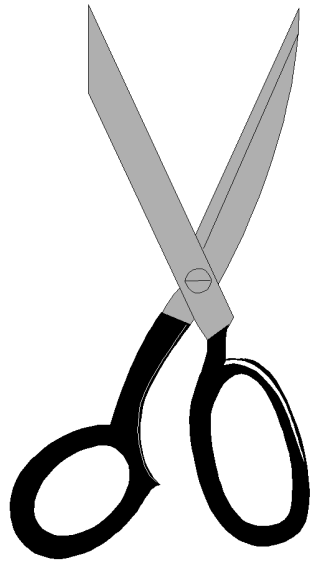

- Utilizza molta energia elettrica.
 - Utilizza poca energia elettrica.
 - Non utilizza alcuna energia elettrica.

CONFRONTARE

Far associare ogni frase all'immagine corrispondente.

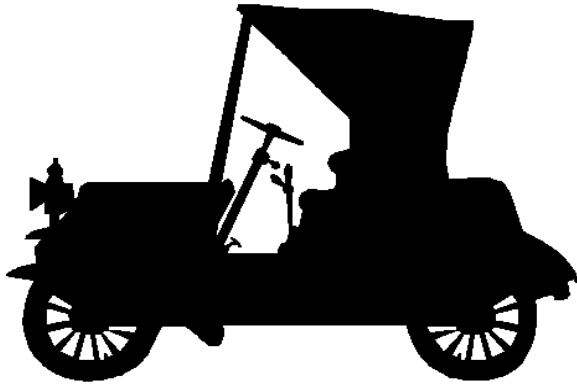

- L'auto più antica.
- L'auto più moderna.

CONFRONTARE

Far associare ogni frase all'immagine corrispondente.

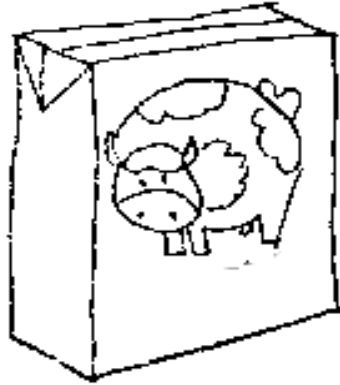

- Il recipiente più adatto per l'acqua.
- Il recipiente più adatto per il vino.

CONFRONTARE

Far associare ogni frase all'immagine corrispondente.

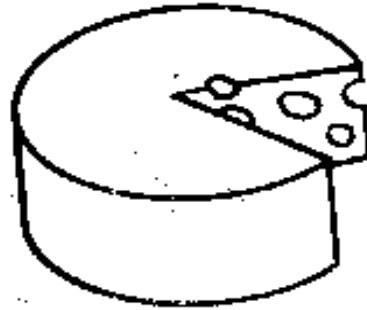
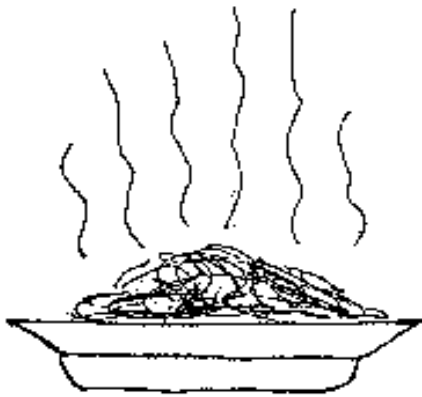

- Il più salato.
- Il più caldo.
- Il più fresco.

CONFRONTARE

Far associare ogni frase all'immagine corrispondente.

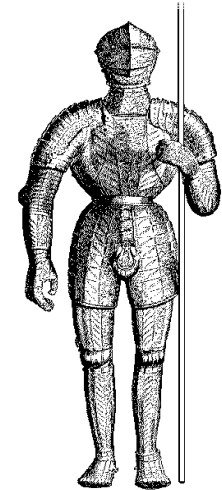
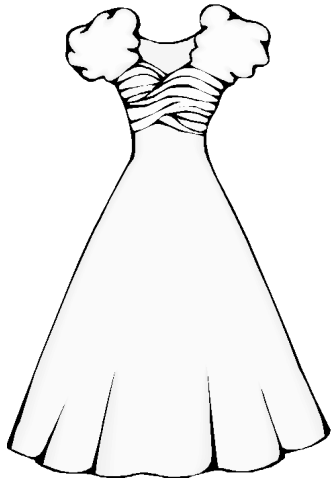

- E' un indumento leggero.
- E' un indumento molto pesante.

CONFRONTARE

Far associare ogni frase all'immagine corrispondente.



- Le piante più alte.
- Le piante più basse.

CONFRONTARE

Far associare ogni frase all'immagine corrispondente.

“ VOGLIA DI CRESCERE ”

PROGRAMMA BASE PER LO SVILUPPO LOGICO E COGNITIVO

I CONTRARI CON IMMAGINI

I CONTRARI CON IMMAGINI

In queste schede il bambino dovrà associare tre parole con i loro rispettivi contrari.

Per essere facilitato in ciò, accanto ad ogni parola, è stata inserita un'immagine che richiama il suo significato.

Quest'attività permetterà al bambino non solo di esercitarsi nella lettura, ma soprattutto di acquisire un vocabolario più ricco di termini e di migliorare la comprensione di quelli già appresi.

UTILIZZAZIONE

SCELTA MULTIPLA INCROCIATA

Per stimolare l'apprendimento s'inviterà il bambino a leggere le parole ed a guardare le immagini che si trovano nel riquadro alla sua sinistra ed a collegarle una ad una con le parole e le immagini che si trovano nel riquadro alla sua destra, specificando che dovrà indicare, di volta in volta, la parola che ha un significato contrario.

In quest'attività il bambino sarà facilitato dal sistema di risposta a scelta multipla incrociata, che gli permetterà di collegare, per esclusione, anche i termini che non conosce, poiché potrà iniziare da quelli a lui noti.

SCELTA APERTA

In un secondo tempo, le stesse schede, potranno essere somministrate al bambino, coprendo la parte destra del foglio.

In questo caso gli si chiederà di dire una parola che sia il contrario di quella letta.

ETÁ DI RIFERIMENTO

Sviluppo linguistico ed intellettuale di almeno otto anni.



INFANTILE

ESTIRPATO

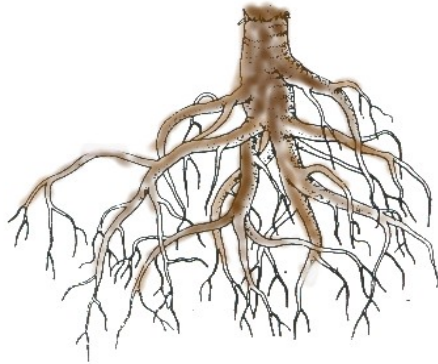

GIOIRE

PATIRE



RADICATO



MATURO



I CONTRARI

Associare ogni termine con il proprio contrario.

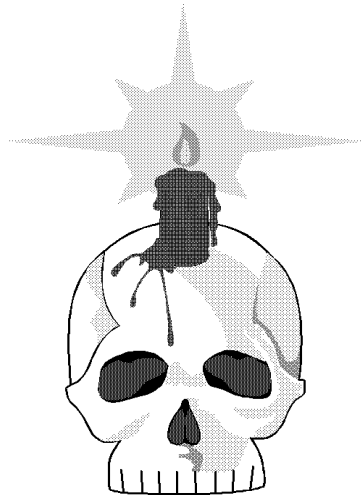

SPAVENTARE



DETESTARE

STIMARE



IGNORANTE



ISTRUITO



CALMARE

I CONTRARI

Associare ogni termine con il proprio contrario.



INCANTEVOLE



REALTA'

FANTASIA



REPELLENTE



VIVACE



FLEMMATICA

I CONTRARI

Associare ogni termine con il proprio contrario.

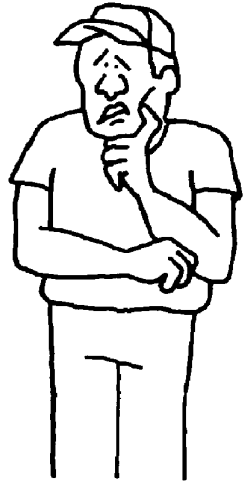

LIBERO

FORTUNATA



APERTO

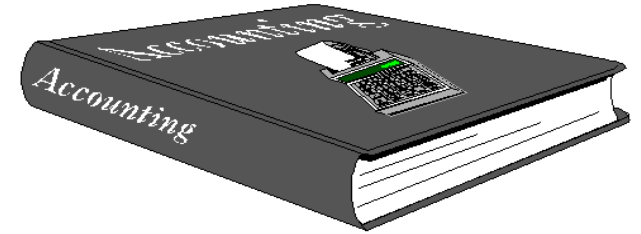

CHIUSO

SFORTUNATA



OCCUPATO



I CONTRARI

Associare ogni termine con il proprio contrario.

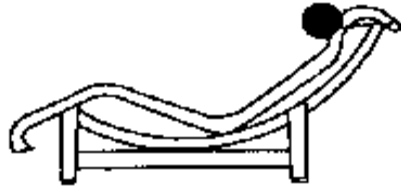

MODERNO



DOCENTE

CHIACCHIERONE



DISCENTE

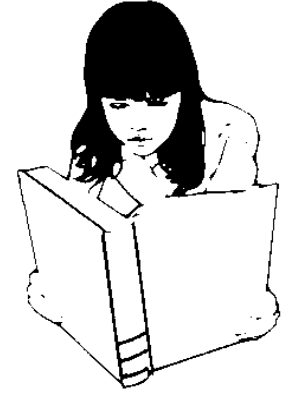

TACITURNO

ANTIQUATO

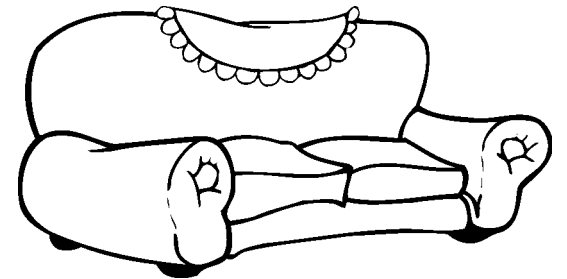

I CONTRARI

Associare ogni termine con il proprio contrario.



EMOTIVA

CODARDO



UMILE

ARROGANTE

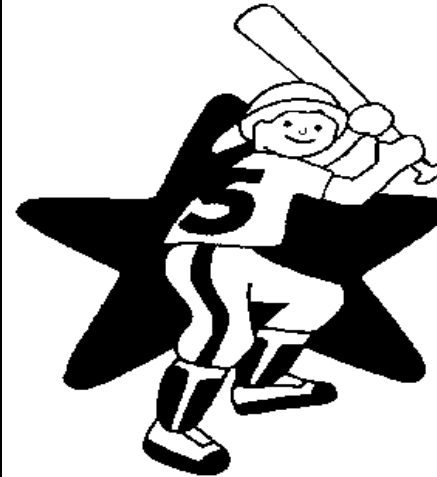

CORAGGIOSO

RAZIONALE



I CONTRARI

Associare ogni termine con il proprio contrario.



DECISA

PIACEVOLE

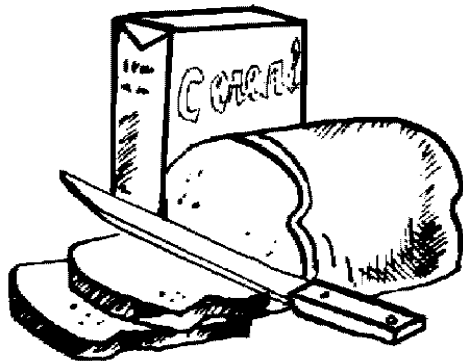

NECESSARIO

ESITANTE

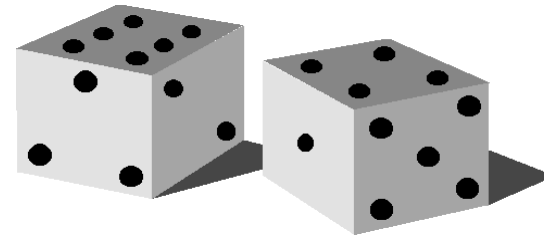

SUPERFLUO

SPIACEVOLE

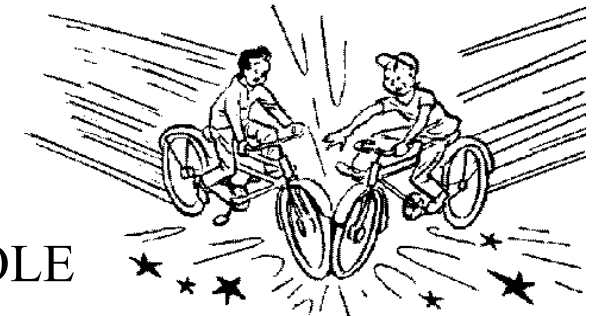

I CONTRARI

Associare ogni termine con il proprio contrario.

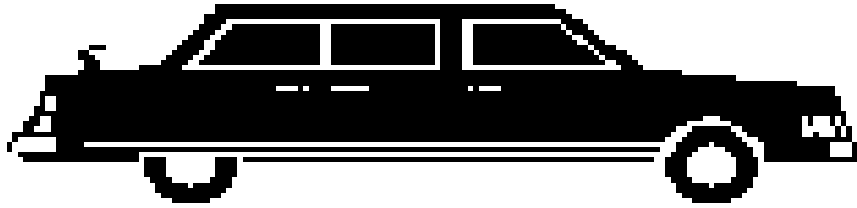

VOLUMINOSA

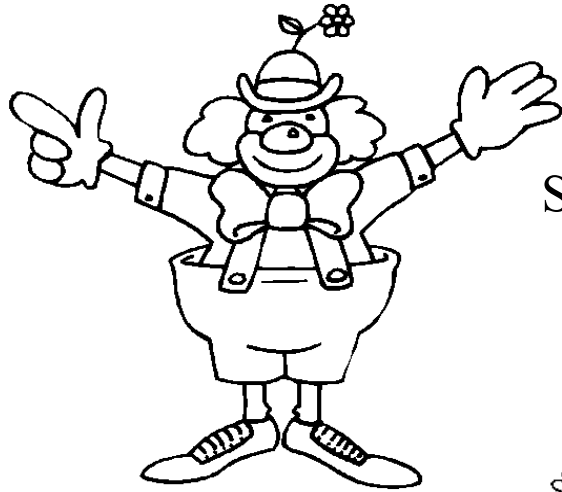

SPIRITOSO

VEZZOSO



PICCOLA

NOIOSO



SGRAZIATO



I CONTRARI

Associare ogni termine con il proprio contrario.

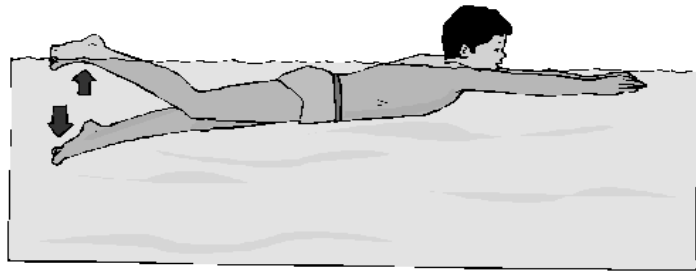

SUPERFICIALE



FALSO



IMPAZIENTE



AUTENTICO

TRANQUILLO



PROFONDO

I CONTRARI

Associare ogni termine con il proprio contrario.



SEVERO



SCRUPOLOSO



PREPOTENTE

NEGLIGENTE



INDULGENTE

ACCOMODANTE

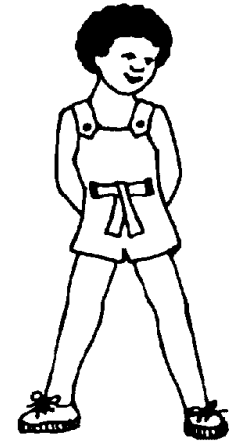

I CONTRARI

Associare ogni termine con il proprio contrario.

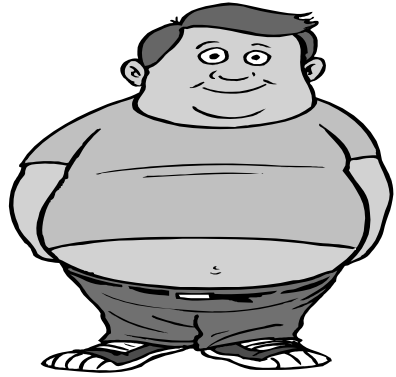

TOZZO



SLANCIATO

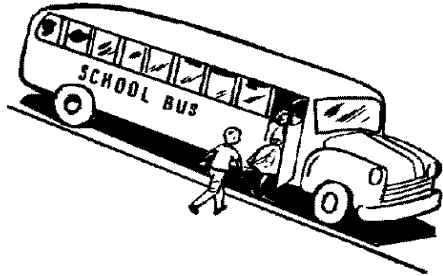

FERMARSÌ

OPACO

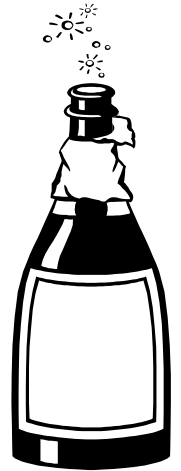

TRASPARENTE



TRANSITARE

I CONTRARI

Associare ogni termine con il proprio contrario.

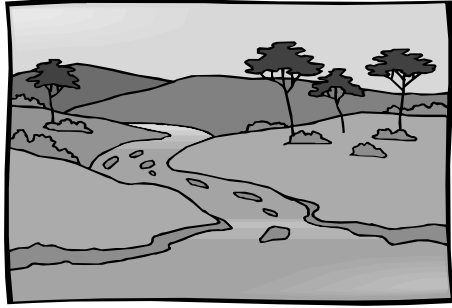

DEFLUIRE

RADO

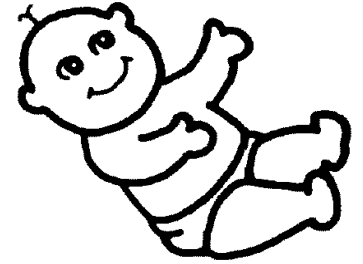

FORESTIERO



ABORIGENO



FOLTO

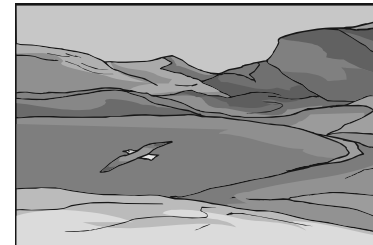

RISTAGNARE

I CONTRARI

Associare ogni termine con il proprio contrario.



VINCERE



AMMIREVOLE

VOLGARE



RAFFINATO

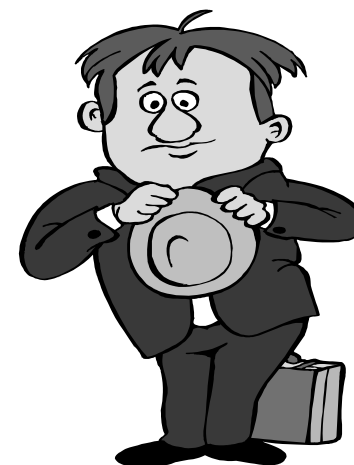

VERGOGNOSO

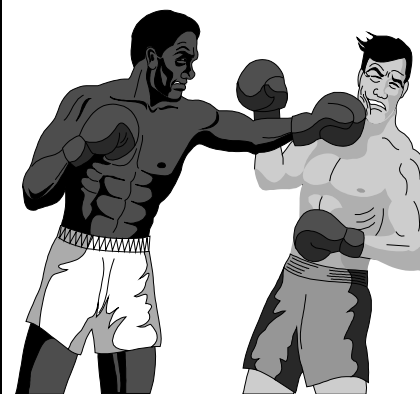

PERDERE

I CONTRARI

Associare ogni termine con il proprio contrario.



STORDIRE



INAFFIDABILE



ORRENDO

RIANIMARE

AFFIDABILE



STUPENDO

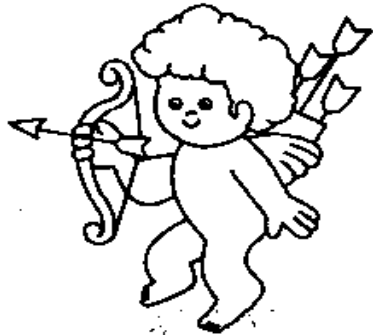

I CONTRARI

Associare ogni termine con il proprio contrario.



ARRUOLATO

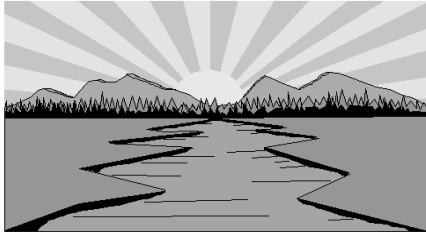

SORGERE



MOTIVATO

DEMOTIVATO



CONGEDATO

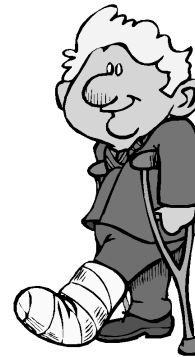

TRAMONTARE



I CONTRARI

Associare ogni termine con il proprio contrario.



TITUBANTE



GELIDO

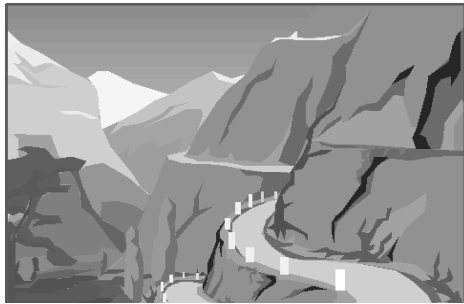

TORTUOSO

REGOLARE



SICURO



TORRIDO



I CONTRARI

Associare ogni termine con il proprio contrario.



COMBATTIVO



VIRTUOSO

VIZIOSO



PERDERE

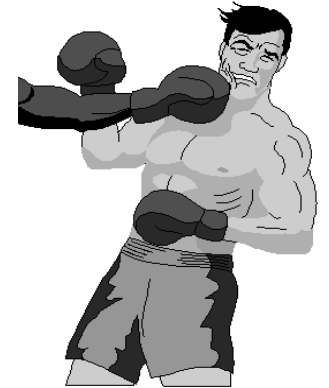

VINCERE



RASSEGNA TO

I CONTRARI

Associare ogni termine con il proprio contrario.

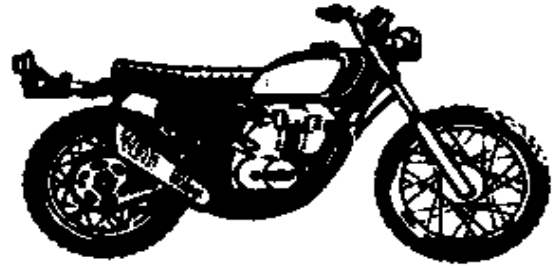

CONCRETO



REALE



VERBALE

ASTRATTO



IDEALE

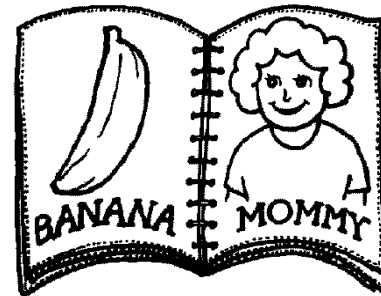

SCRITTO

I CONTRARI

Associare ogni termine con il proprio contrario.



ACCORDARSI

PASSEGGERO

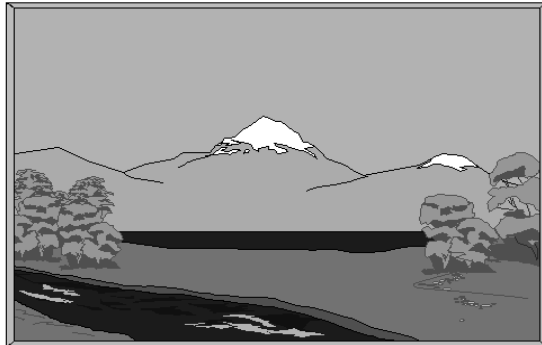

SERENO



DURATURO



AVVERSO



LITIGARE

I CONTRARI

Associare ogni termine con il proprio contrario.



FARE



AVERE A CUORE

IMBRANATO



DISINVOLTO

DISFARE

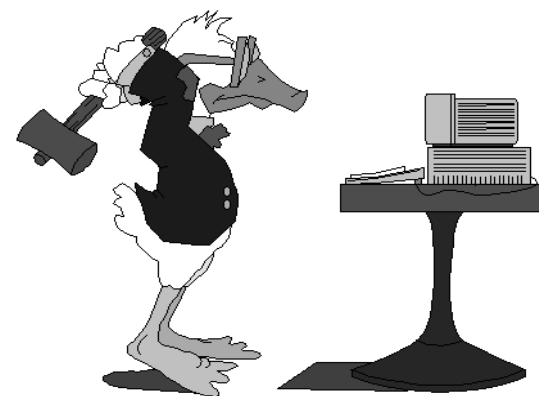

DISINTERESSARSI



I CONTRARI

Associare ogni termine con il proprio contrario.



COMICO



FURBO

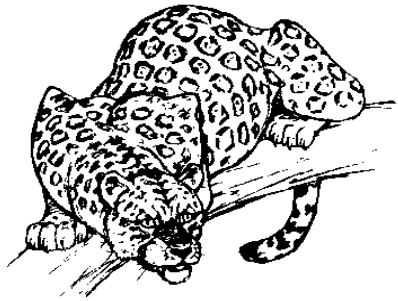

EQUATORIALE

POLARE



INGENUO

DRAMMATICO



I CONTRARI

Associare ogni termine con il proprio contrario.



CELESTE

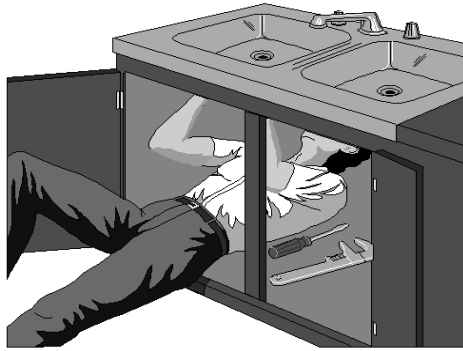

RIPARARE



SFRENATO

TERRENO



MODERATO

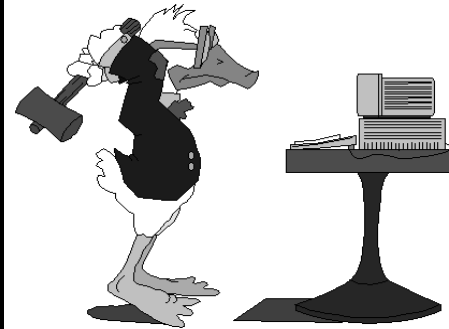

DISTRUGGERE

I CONTRARI

Associare ogni termine con il proprio contrario.



UMORISTICO

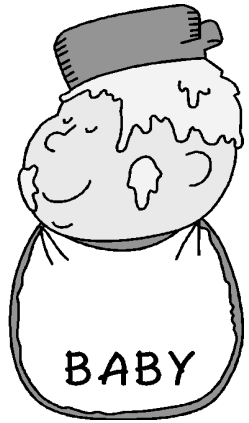

UNGERE

USUALE



SERIO

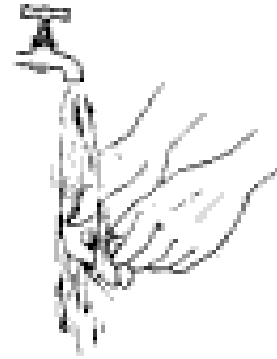

SGRASSARE

INSOLITO

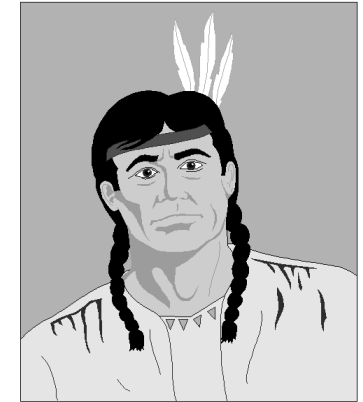

I CONTRARI

Associare ogni termine con il proprio contrario.



INFANTILE

ESTIRPATO

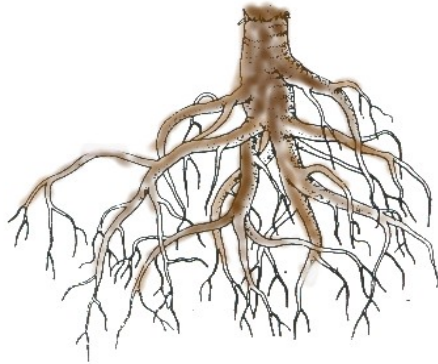

GIOIRE



I CONTRARI

Per ogni parola far esprimere verbalmente il proprio contrario.

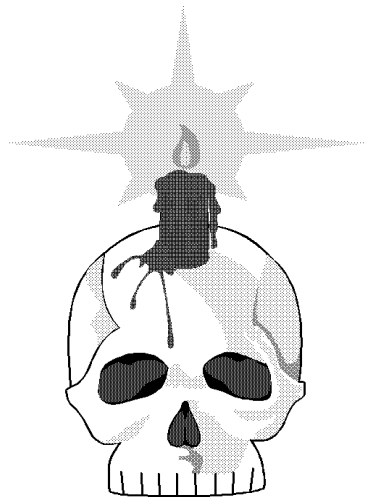

SPAVENTARE

STIMARE

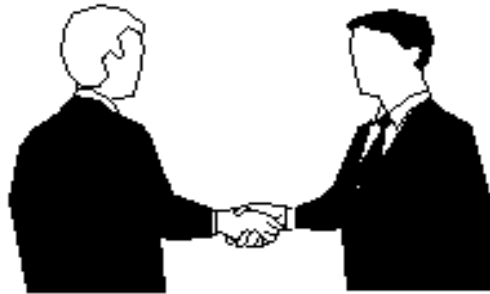

ISTRUITO



I CONTRARI

Per ogni parola far esprimere verbalmente il proprio contrario.



INCANTEVOLE

FANTASIA



VIVACE



I CONTRARI

Per ogni parola far esprimere verbalmente il proprio contrario.

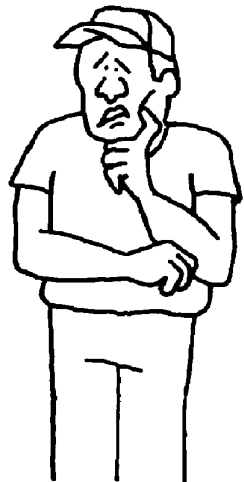

LIBERO

FORTUNATA



APERTO



I CONTRARI

Per ogni parola far esprimere verbalmente il proprio contrario.

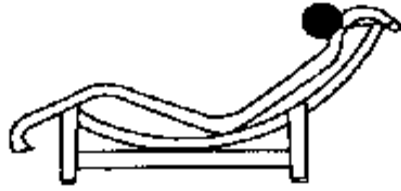

MODERNO



DOCENTE

CHACCHIERONE



I CONTRARI

Per ogni parola far esprimere verbalmente il proprio contrario.



EMOTIVA

CODARDO



UMILE



I CONTRARI

Per ogni parola far esprimere verbalmente il proprio contrario.



DECISA

PIACEVOLE

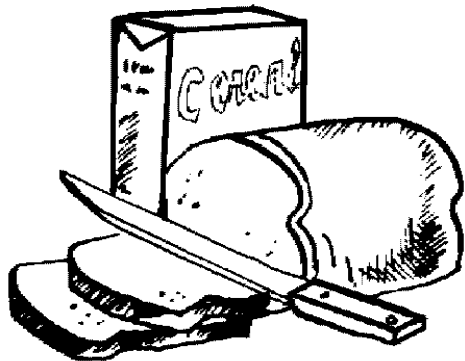

NECESSARIO



I CONTRARI

Per ogni parola far esprimere verbalmente il proprio contrario.

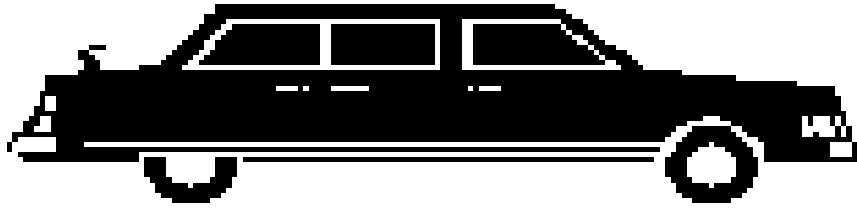

VOLUMINOSA

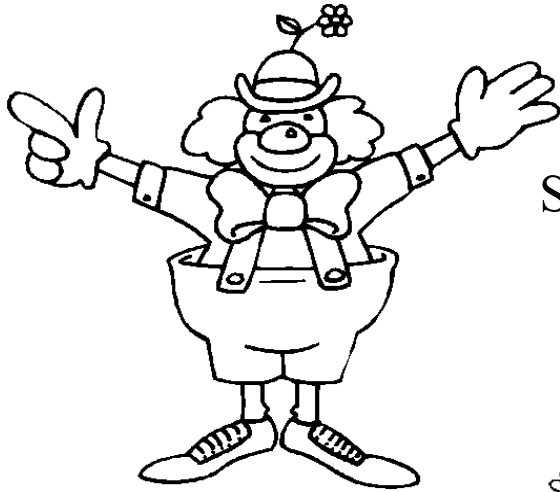

SPIRITOSO

VEZZOSO



I CONTRARI

Per ogni parola far esprimere verbalmente il proprio contrario.

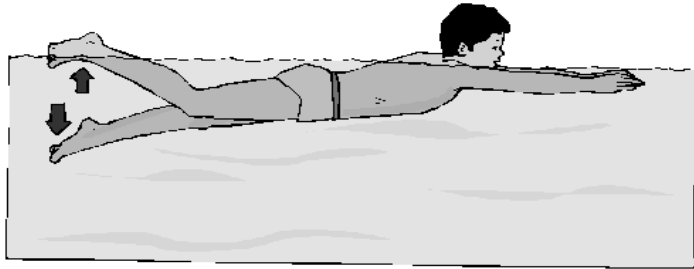

SUPERFICIALE



FALSO



IMPAZIENTE



I CONTRARI

Per ogni parola far esprimere verbalmente il proprio contrario.



SEVERO



SCRUPOLOSO



PREPOTENTE



I CONTRARI

Per ogni parola far esprimere verbalmente il proprio contrario.

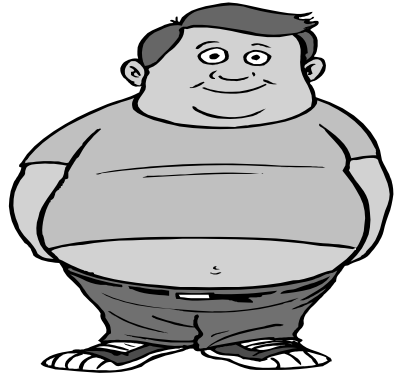

TOZZO

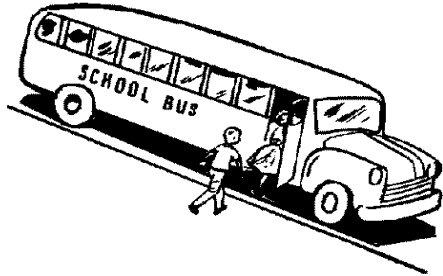

FERMARSÌ



TRASPARENTE



I CONTRARI

Per ogni parola far esprimere verbalmente il proprio contrario.

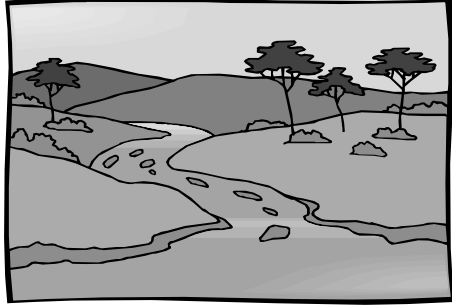

DEFLUIRE



FORESTIERO



FOLTO

I CONTRARI

Per ogni parola far esprimere verbalmente il proprio contrario.



VINCERE

VOLGARE



VERGOGNOSO



I CONTRARI

Per ogni parola far esprimere verbalmente il proprio contrario.



STORDIRE



AFFIDABILE

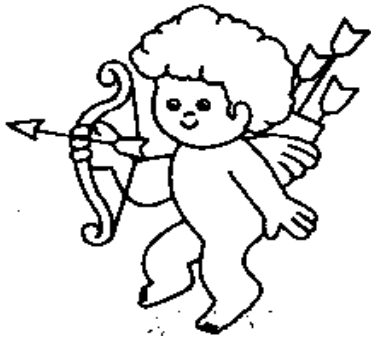

STUPENDO



I CONTRARI

Per ogni parola far esprimere verbalmente il proprio contrario.



ARRUOLATO

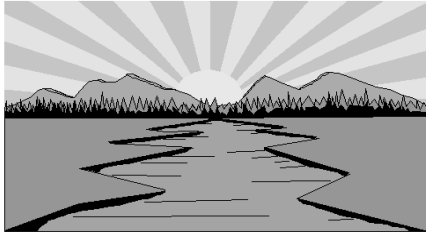

SORGERE



MOTIVATO



I CONTRARI

Per ogni parola far esprimere verbalmente il proprio contrario.



TITUBANTE



GELIDO

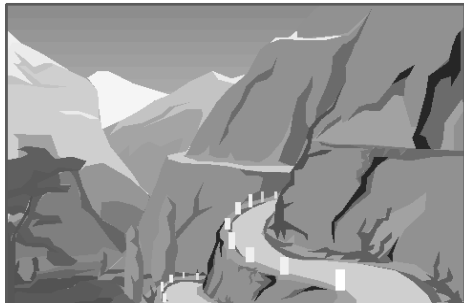

TORTUOSO



I CONTRARI

Per ogni parola far esprimere verbalmente il proprio contrario.



COMBATTIVO

VIZIOSO



VINCERE



I CONTRARI

Per ogni parola far esprimere verbalmente il proprio contrario.

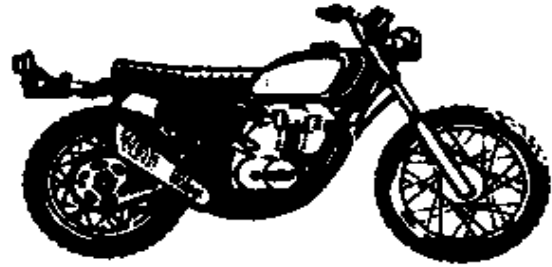

CONCRETO



REALE



VERBALE



I CONTRARI

Per ogni parola far esprimere verbalmente il proprio contrario.



ACCORDARSI

PASSEGGERO

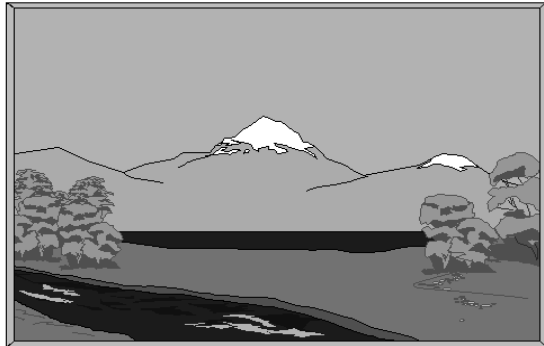

SERENO



I CONTRARI

Per ogni parola far esprimere verbalmente il proprio contrario.



FARE



AVERE A CUORE



IMBRANATO



I CONTRARI

Per ogni parola far esprimere verbalmente il proprio contrario.



COMICO



FURBO

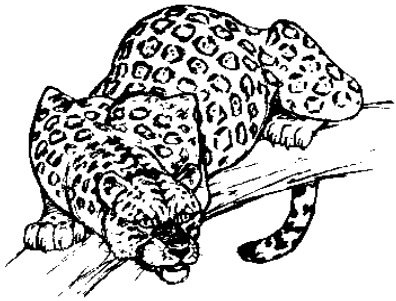

EQUATORIALE



I CONTRARI

Per ogni parola far esprimere verbalmente il proprio contrario.



CELESTE

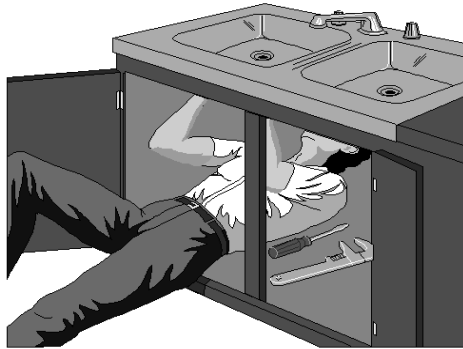

RIPARARE



SFRENATO



I CONTRARI

Per ogni parola far esprimere verbalmente il proprio contrario.



UMORISTICO

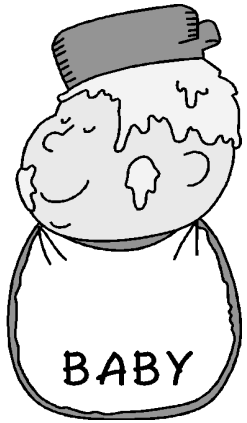

UNGERE

BABY

USUALE



I CONTRARI

Per ogni parola far esprimere verbalmente il proprio contrario.

“ VOGLIA DI CRESCERE ”

PROGRAMMA BASE PER LO SVILUPPO LOGICO E COGNITIVO

I SINONIMI CON IMMAGINI

I SINONIMI CON IMMAGINI

In queste schede il bambino dovrà associare ogni parola con il rispettivo sinonimo. Per facilitare il riconoscimento del significato, ogni parola è stata corredata da un'immagine.

Quest'attività gli potrà permettere di esercitarsi nella lettura, di acquisire un vocabolario più ricco di termini e di migliorare la comprensione di quelli già appresi.

UTILIZZAZIONE

SCELTA MULTIPLA INCROCIATA

Per stimolare l'apprendimento s'inviterà il bambino a leggere, le parole sotto le immagini che si trovano nella parte sinistra della scheda collegandole con i sinonimi che si trovano nella parte destra.

In quest'attività il bambino sarà facilitato dalle immagini e dal sistema di risposta a scelta multipla incrociata, che gli permetterà di collegare, per esclusione, anche i termini che non conosce, poiché potrà iniziare da quelli a lui noti.

SCELTA APERTA

In un secondo tempo, coprendo la parte destra della scheda, il bambino dovrà dire un sinonimo della parola letta anche se diverso da quello presente nella scheda.

ETÀ DI RIFERIMENTO

Sviluppo linguistico ed intellettuale di almeno otto anni.



SALVEZZA

SBARAZZARE



SGOMBERARE

SATIRICO



SPIRITOSO

GRAZIA

I SINONIMI

Associare ogni termine con il proprio sinonimo.



MISSIONE

MOSTRARE



MOTIVARE

COMPITO

INCENTIVARE

ESIBIRE

I SINONIMI

Associare ogni termine con il proprio sinonimo.

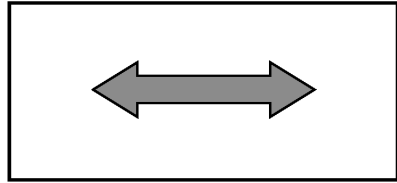

LARGHEZZA



LEALE



LEGALE

CORRETTO

AMPIEZZA

LECITO

I SINONIMI

Associare ogni termine con il proprio sinonimo.



TURBATO



DIFENDERE



UMORE

SCOSSO

SPIRITO

TUTELARE

I SINONIMI

Associare ogni termine con il proprio sinonimo.

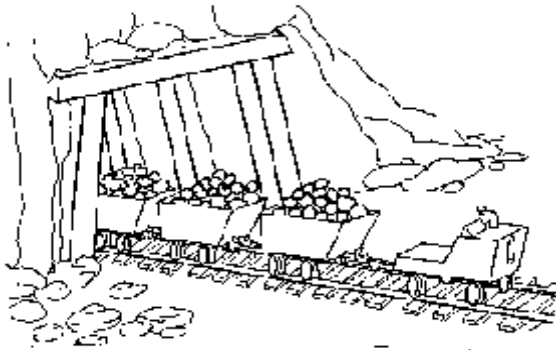

GALLERIA



LANCIARE



SUPPORTO

SOSTEGNO

GETTARE

TRAFORO

I SINONIMI

Associare ogni termine con il proprio sinonimo.



PORZIONE

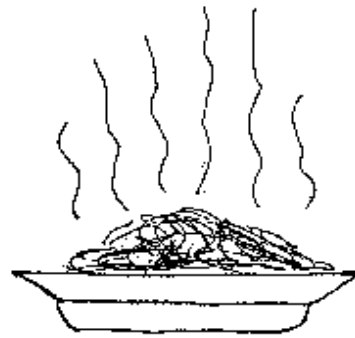

PIETANZA



PENSARE

PARTE

CIBO

RIFLETTERE

I SINONIMI

Associare ogni termine con il proprio sinonimo.



LETIZIA



LEZIONE



LIBRO

FELICITA'

TOMO

CORSO

I SINONIMI

Associare ogni termine con il proprio sinonimo.



ARMATA

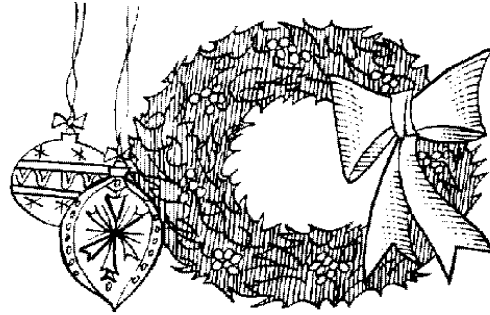

ADDOBBO



ASSASSINO

ESERCITO

OMICIDA

ARREDO

I SINONIMI

Associare ogni termine con il proprio sinonimo.



GITANO



NEGLIGENZA

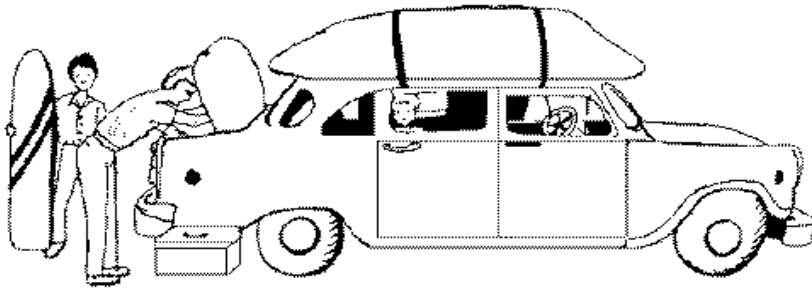

CARICARE

NOMADE

INCURIA

OBERARE

I SINONIMI

Associare ogni termine con il proprio sinonimo.

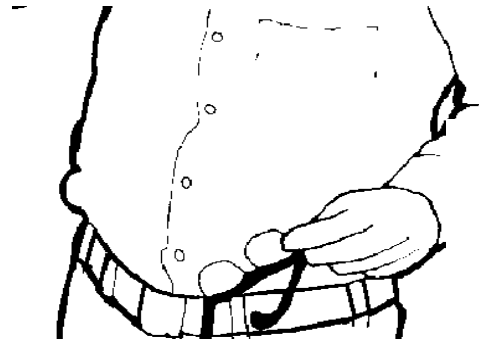

PANCIA



PAPA

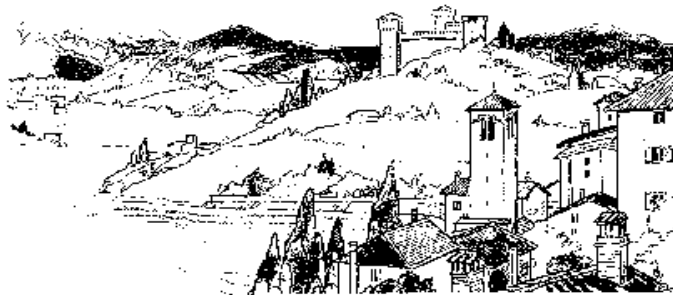

PANORAMA

PONTEFICE

VENTRE

VEDUTA

I SINONIMI

Associare ogni termine con il proprio sinonimo.

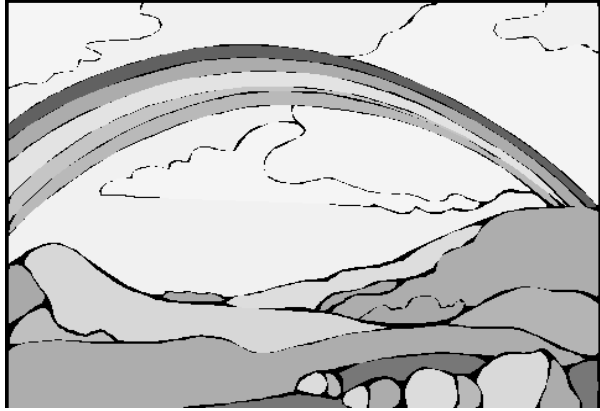

CIELO



CIABATTE



CLAVA

EMPIREO

RANDELLO

PANTOFOLE

I SINONIMI

Associare ogni termine con il proprio sinonimo.

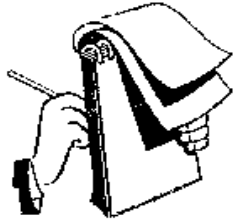

NOTA



NOTIZIA



NAUFRAGARE

PUNTO

AFFONDARE

AVVISO

I SINONIMI

Associare ogni termine con il proprio sinonimo.



DENARO



AVVILITO

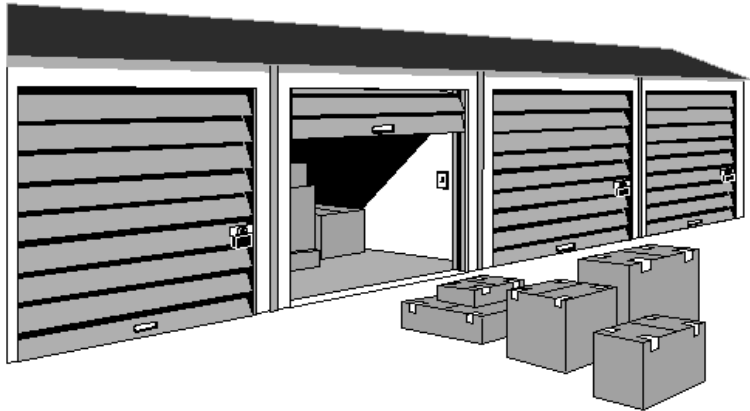

DEPOSITO

DEPRESSO

CAPITALE

MAGAZZINO

I SINONIMI

Associare ogni termine con il proprio sinonimo.



NATURA



NEGOZIARE



ILLUSTRE

CREATO

NOBILE

TRATTARE

I SINONIMI

Associare ogni termine con il proprio sinonimo.

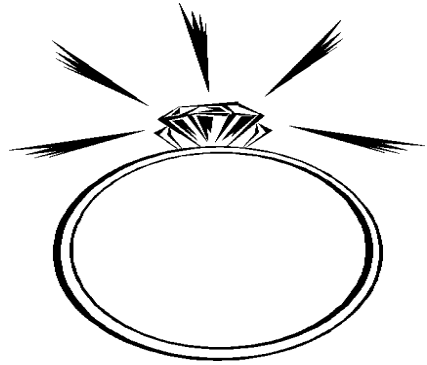

GIOIELLO



GIUDICE



GLORIA

ARBITRO

GEMMA

TRIONFO

I SINONIMI

Associare ogni termine con il proprio sinonimo.

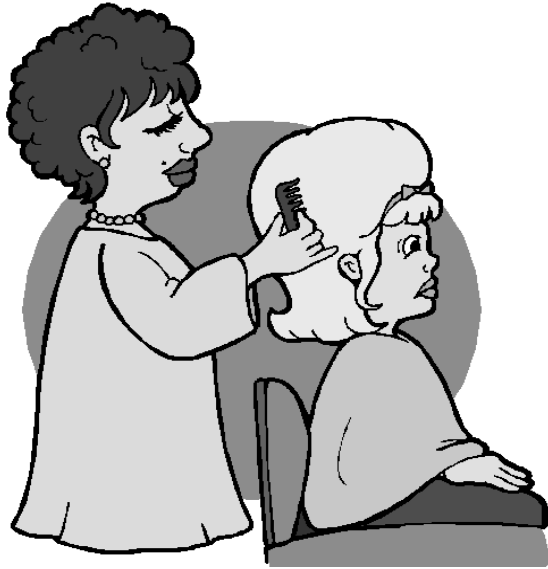

ACCONCIARE

PACATO

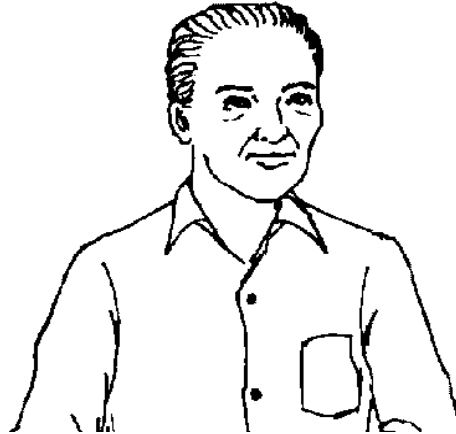

RASARE

ORNARE



RADERE

COMPOSTO

I SINONIMI

Associare ogni termine con il proprio sinonimo.



EDUCARE



ENERGIA



EFFIGE

IMMAGINE

FORZA

FORMARE

I SINONIMI

Associare ogni termine con il proprio sinonimo.

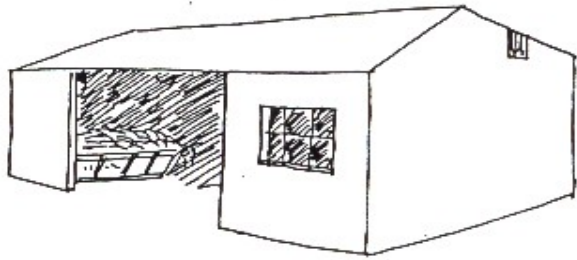

FATTORIA

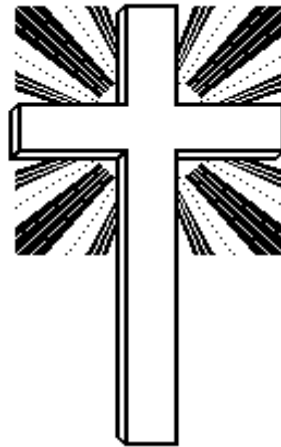

FEDE

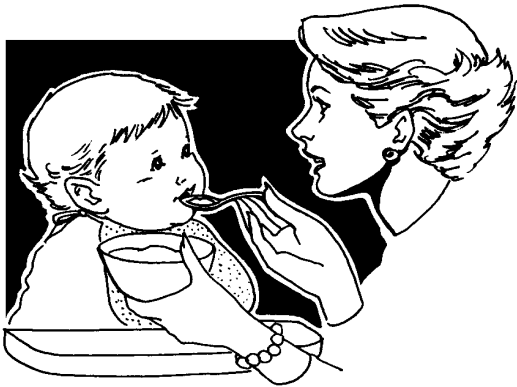

FIDUCIA

CREDO

AFFIDAMENTO

CASCINA

I SINONIMI

Associare ogni termine con il proprio sinonimo.

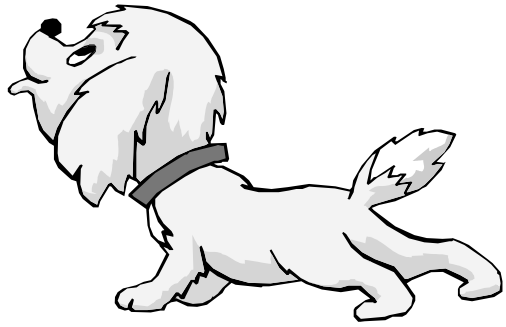

ANNUSARE

FIUTARE

ANTENATO



PROGENITORE



APOSTOLO

SEGUACE

I SINONIMI

Associare ogni termine con il proprio sinonimo.



LIQUIDO

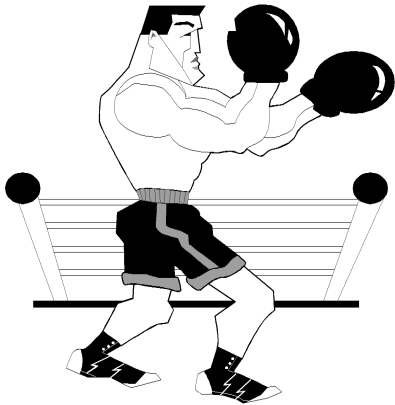

LOTTA



CATALOGO

LISTA

DISPUTA

FLUIDO

I SINONIMI

Associare ogni termine con il proprio sinonimo.



GARA



GIOCARE



BABY

GOLOSO

GHIOTTO

SVAGARSI

COMPETIZIONE

I SINONIMI

Associare ogni termine con il proprio sinonimo.



INDICE



INGANNO



INGORDO

TRUFFA

AVIDO

ELENCO

I SINONIMI

Associare ogni termine con il proprio sinonimo.



VIRTU'

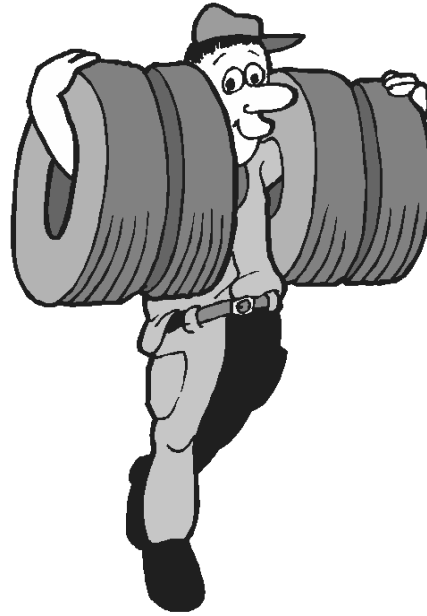

PESO



ZUPPO

FRADICIO

ZAVORRA

VALORE

I SINONIMI

Associare ogni termine con il proprio sinonimo.



UBRIACO

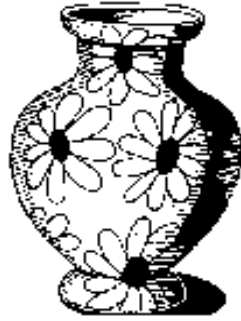

VASO



SPAZIO

BRILLO

UNIVERSO

URNA

I SINONIMI

Associare ogni termine con il proprio sinonimo.

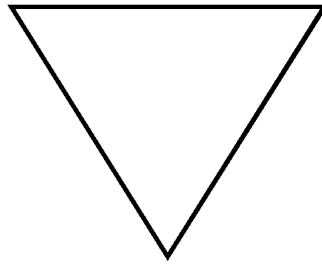
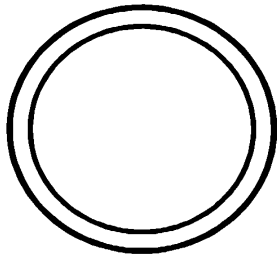
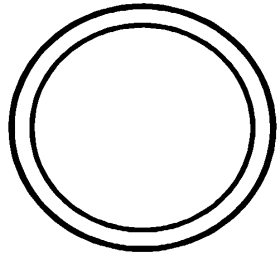

SCELTA



SEGUIRE



TAGLIARE

BRACCARE

OPZIONE

TRANCIARE

I SINONIMI

Associare ogni termine con il proprio sinonimo.

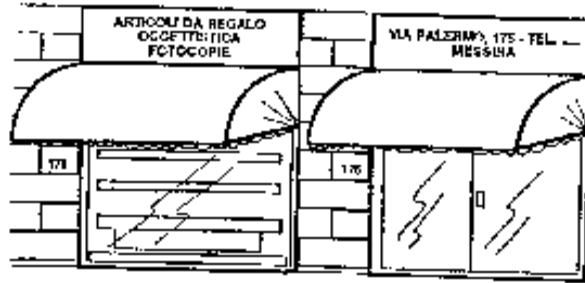

INSEGNA

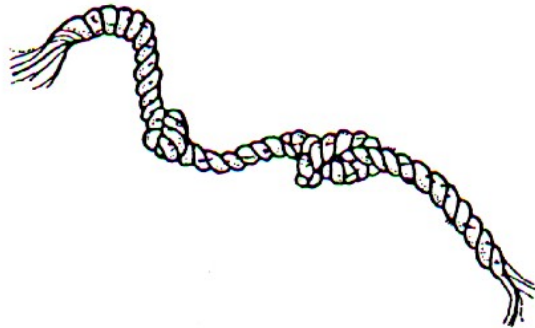

LACCIO

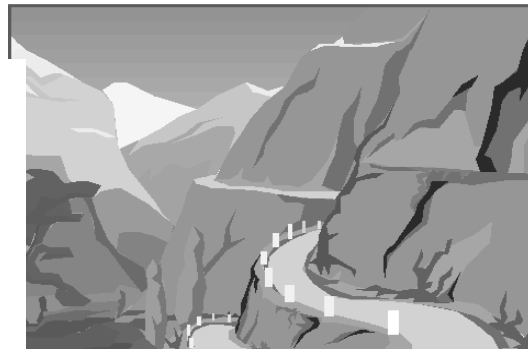

PERCORSO

ITINERARIO

TARGA

CORDA

I SINONIMI

Associare ogni termine con il proprio sinonimo.



CRONACA

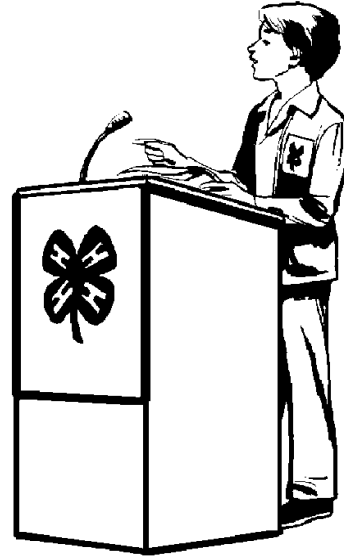

DEPUTATO



CREDENTE

INCARICATO

DEVOTO

DESCRIZIONE

I SINONIMI

Associare ogni termine con il proprio sinonimo.

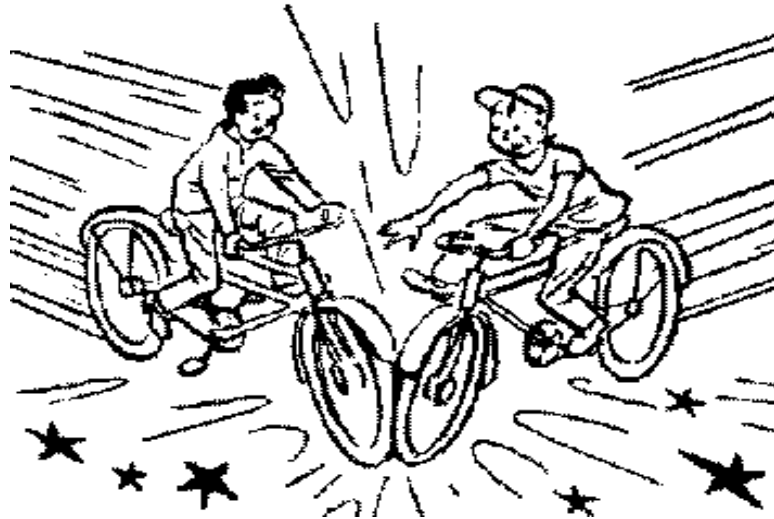

URTO



PASSEGGIATA



VALICO

COLPO

PASSAGGIO

USCITA

I SINONIMI

Associare ogni termine con il proprio sinonimo.